



ITT



Shock and Vibration Products

CR Series



Engineered for life





U.S. Patents 6,290,217
6,244,579

Compact Wire Rope Isolators

For the best in vibration isolation capabilities, choose Enidine's Compact Wire Rope Isolators. Smaller than traditional wire ropes, these unique isolators provide cost-effective, simultaneous shock and vibration attenuation where package space is at a premium.

Enidine Compact Wire Rope Isolators feature an easy, single-point installation, which allows them to be installed in virtually any application. Their small size also permits the isolation of individual system components, making them ideal for use in sensitive equipment and electronics. Just as with our standard Enidine Wire Rope Isolators, Enidine Compact Wire Rope Isolators feature a patented, all-metal design and components that ensure maximum reliability, regardless of temperature or substrate requirement, and that can help meet MILSPECS similar to those of our Wire Rope Isolator series. Please refer to our "Compact Wire Rope Isolator Sizing Information" on pages 149-150 for more information.

If your application is outside the standard Compact Wire Rope Isolator product range, please consult the standard Wire Rope Isolator or HERM portions of this catalog. If a standard solution is still not available, Enidine engineers can design an isolator to suit your specifications.

For further information on Enidine Wire Rope, HERM and Compact Wire Rope Isolator products, technical assistance and pricing, please contact Enidine or your nearest authorized distributor. A list of Enidine distributors can be found by visiting our website at www.enidine.eu.

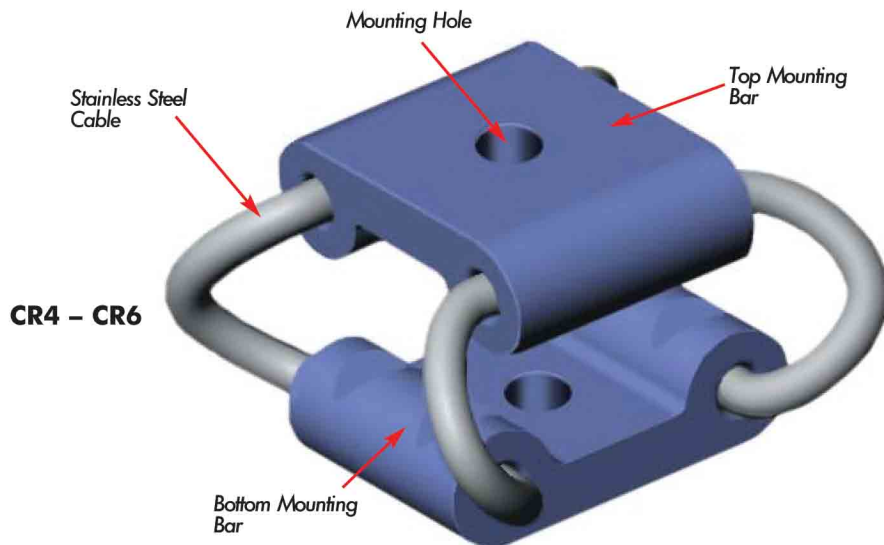
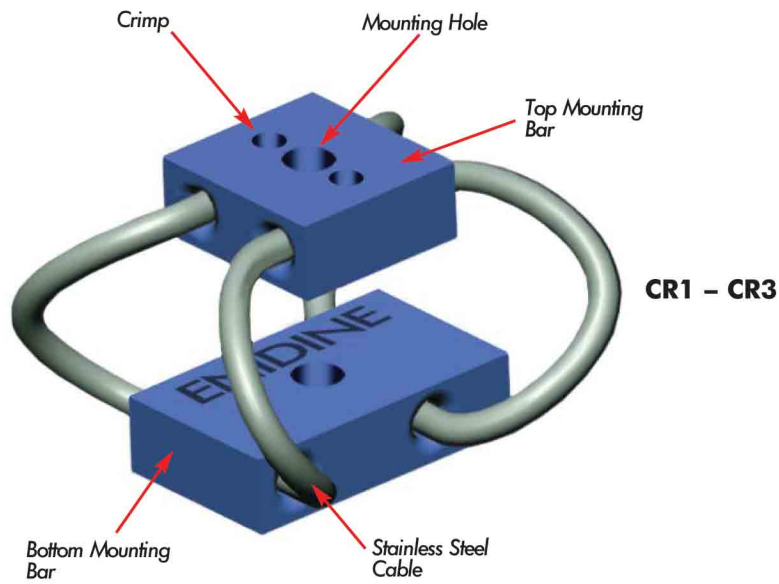

Materials and Finishes:

- Standard:** Wire Rope: 302/304 Stainless Steel
 Mount Bars: 6061-T6 Aluminum, Chemical Conversion Coated per MIL-C-5541, Class 1A
 Threads: Tapped
- Optional:** Mount Bars: 6061-T6 Aluminum, Anodized per MIL-A-8625, Type II, Class 1
 302/304 Stainless Steel per ASTM A276, Passivated
- Special:** Consult Enidine

Isolator Options:

- Mounting:** Enidine offers a full range of mounting combinations of thru-hole, countersunk, and threaded bars. All configurations are available in either Imperial or Metric styles. Add an "M" after the mounting option for Metric. Some models have reduced mounting options available due to limited fastener installation space. Consult Enidine if a preferred mounting configuration is not listed.
- Bellmouth:** The bellmouth feature includes mount bars with radii manufactured into the wire rope hole edges. This option is recommended for high fatigue applications. Compact rope models (CR1 – CR6) include this feature as the standard.

Performance:

Stiffness (Kv or Ks):

Compact wire rope isolators exhibit non-linear stiffness behavior. Small deflections, usually associated with vibration isolation, will have a different spring rate than larger shock deflections. Enidine publishes typical vibration stiffness values (Kv), and average shock stiffness values (Ks) within the catalog. These values can be used with the provided equations listed on Page 150 to predict system performance.

Isolator Axes:

Compact wire rope isolators are multi-axis isolators. The diagram below includes load axis definitions and deflection considerations.

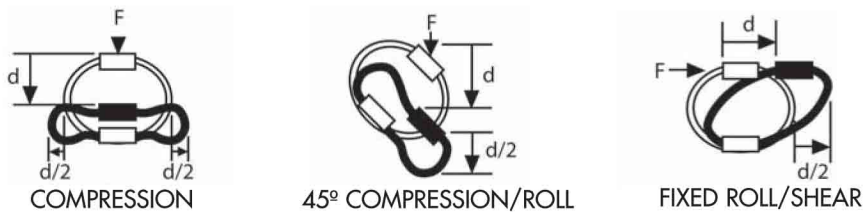

Damping: Typically 5-15%, depending on size and input level. For specific damping considerations, please consult Enidine.

Mounting Orientation:

The diagrams below illustrate typical mounting orientations.

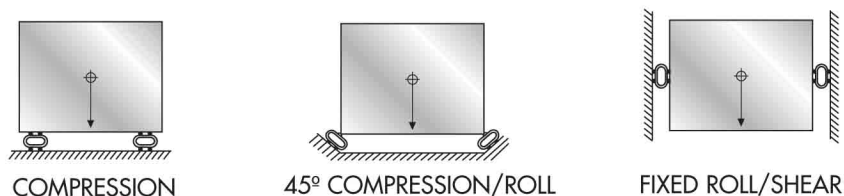

Stabilizers:

Stabilizers are used to control deflections of tall supported masses. Stabilizers are typically recommended when the height equals 2-times the width or depth dimension. In most applications, the quantity of stabilizers required are half as many as the base isolators, and selected one size softer than the base isolators.

APPLICATION WORKSHEET - INPUTS METRIC		METRIC
PART I: SYSTEM DATA:		
1. Total Supported Load (W _T):	$W_T = \text{_____ Kg} \times 9,81 = \text{_____ N}$	
2. Number of Isolators (n):	$n = \text{_____}$	
3. Static Load per Isolator (W):	$W = \frac{W_T}{n}$	$W = \text{_____ N}^*$
* Assumes a central CG		
4. Load Axis: Compression Shear or Roll 45° Compression/Roll		Load Axis _____
PART II: VIBRATION SIZING:		
1. Input Excitation Frequency	$f_i = \text{_____ Hz} \left(= \frac{\text{rpm}}{60} \right)$	
2. System Response Natural Frequency for 80% isolation:	$f_n = \frac{f_i}{3,0} = \text{_____ Hz}$	
3. Maximum Isolator Vibration Stiffness: (K _v)	$K_v = \frac{W (2\pi f_n)^2}{g}$ $g = 9,81 \text{ m/s}^2$	$K_v = \text{_____ N/m}$
4. Select an isolator by comparing calculated values with technical data for the desired load axis provided in tables for each isolator. a.) Calculated "W" must be less than the isolator's max static load and b.) Isolator's vibration stiffness must be less than the calculated maximum K _v .		
PART III: SHOCK SIZING:		
1. Maximum Allowable Transmitted Acceleration:	$A_T = \text{_____ G's}$	
2. Shock Input Velocity:	$V = \text{_____ m/s}$	
Free Fall Impact:	$V = \sqrt{2gh}$ $g = 9,81 \text{ m/s}^2$ $h = \text{Drop Height (m)}$	
3. Min. Isolator Response Deflection:	$D_{\min} = \frac{V^2}{g(A_T)}$	$D_{\min} = \text{_____ m}$
4. Maximum Isolator Shock Stiffness:	$K_s = \frac{W(V/D_{\min})^2}{g}$	$K_s = \text{_____ N/m}$
5. Select an isolator by comparing calculated values with technical data for the desired load axis provided in tables for each isolator. a.) Calculated "W" must be less than the isolator's max static load and b.) Calculated D _{min} must be less than the isolator's max deflection Note: Metric deflections are calculated in meters (m) and technical data is in millimeters (mm). and c.) Isolator's shock stiffness must be less than calculated maximum "K _s "		
6. Check actual deflection using "K _s " from technical data to ensure that the isolator's max deflection is not exceeded.	$D_{\text{actual}} = \sqrt{\frac{K_s(\text{Isolator})g}{W}}$	$D_{\text{actual}} = \text{_____ m}$
7. If isolator's max deflection is exceeded, select another isolator and repeat steps 5 and 6.		

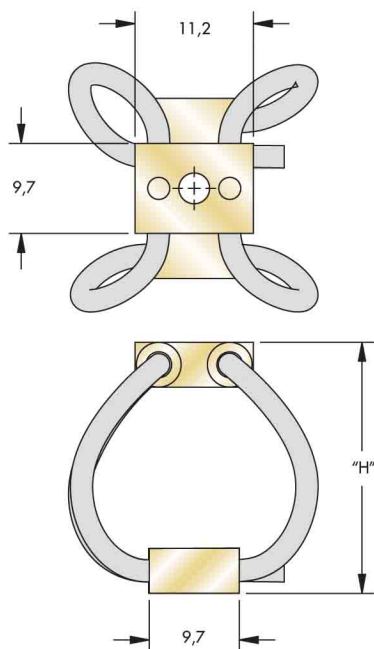

Note: Dimensions are in mm
Tolerances are ± .25mm

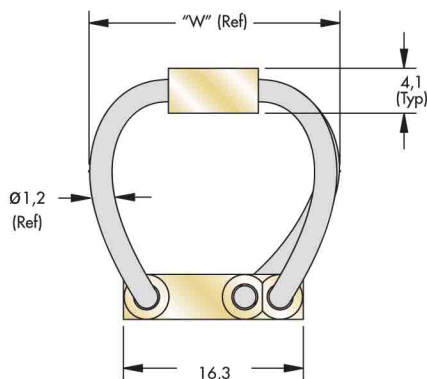

Size	Height "H" mm	Width Ref "W" mm	Unit Weight g	Mounting Options	Thru Hole mm	Thread mm (in.)	C'sink Metric (Imperial)
CR1-100	17	19	3,1	A, B, C, D, E, S	Ø3,30	M3 X 0,5 (#4-40 UNC)	90° (82°)
CR1-200	19	20	3,1				
CR1-300	23	23	3,4				
CR1-400	26	26	3,4				

Model Number Ordering Code

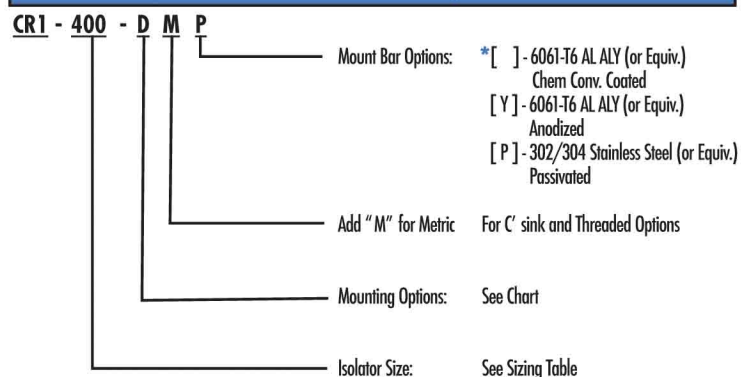

* Standard features. Any non-standard items may require longer lead times. Call for quotation.

Mounting Options

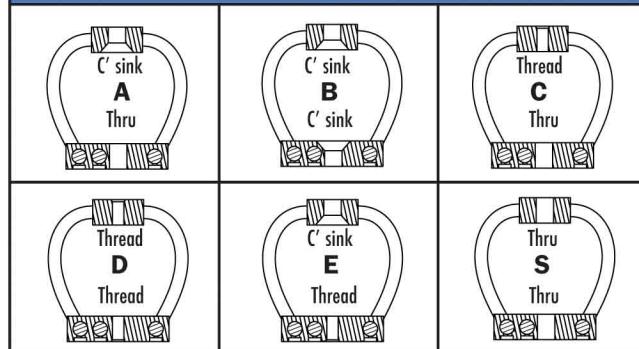

- Maximum recommended torque for tapped aluminum bar is 1,2 Nm
- Wire Rope Material: Stranded 300 series stainless steel
- Operating Temperature Range: -100°C to 260°C
- U.S. Patent 6,290,217

Static Load vs. Deflection

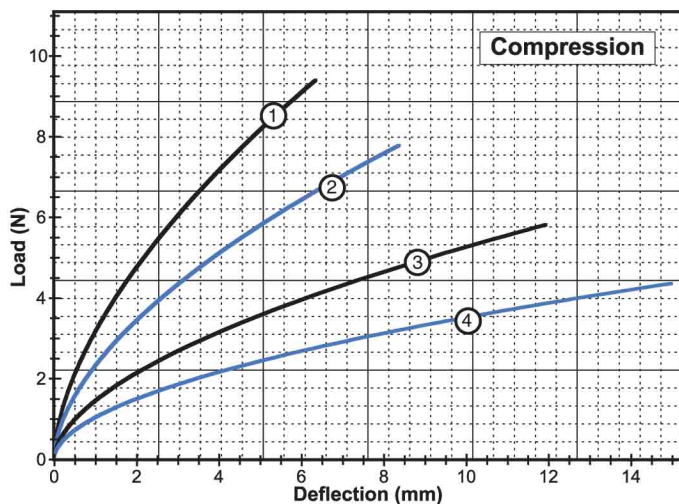

Compression

Curve	Model	Max Static Load N	Max Deflection mm	Kv (vibration) kN/m	Ks (shock) kN/m
1	CR1-100	3,3	6,4	3,9	1,9
2	CR1-200	2,4	8,4	2,8	1,2
3	CR1-300	1,8	11,9	1,75	0,61
4	CR1-400	1,3	15,0	1,31	0,39

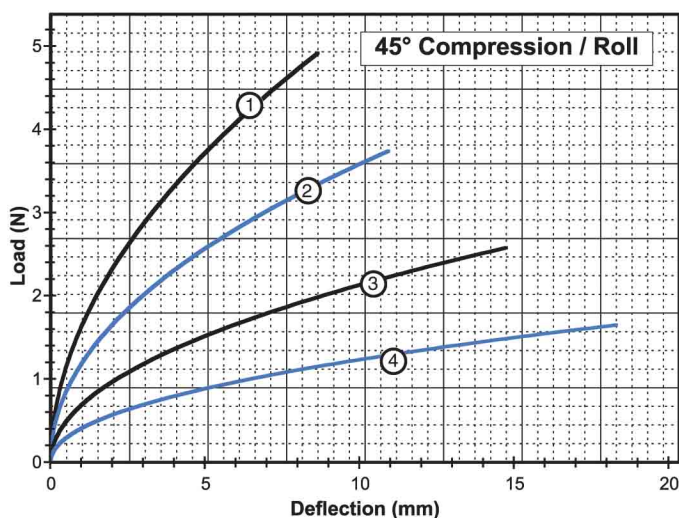

45° Compression/Roll

Curve	Model	Max Static Load N	Max Deflection mm	Kv (vibration) kN/m	Ks (shock) kN/m
1	CR1-100	1,6	8,6	2,1	0,79
2	CR1-200	1,1	10,9	1,5	0,44
3	CR1-300	0,76	14,7	0,88	0,26
4	CR1-400	0,49	18,3	0,53	0,12

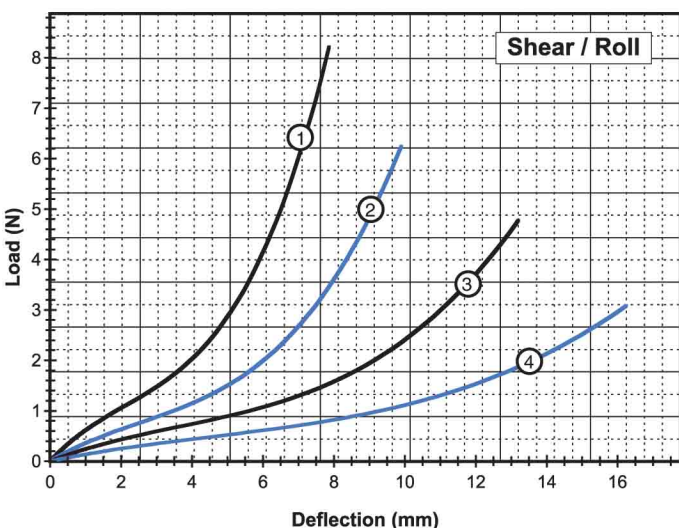

Shear/Roll

Curve	Model	Max Static Load N	Max Deflection mm	Kv (vibration) kN/m	Ks (shock) kN/m
1	CR1-100	1,1	7,9	0,70	0,70
2	CR1-200	0,89	9,9	0,44	0,44
3	CR1-300	0,71	13,2	0,26	0,26
4	CR1-400	0,53	16,3	0,13	0,13

Note: Do not extrapolate plotted curves.

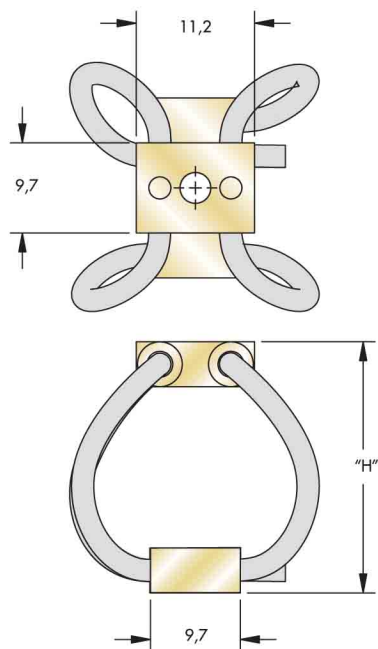

Note: Dimensions are in mm
Tolerances are $\pm .25$ mm

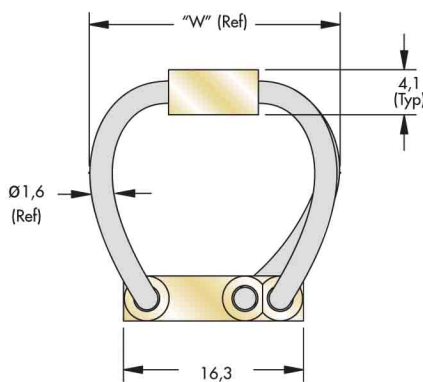

Size	Height "H" mm	Width Ref "W" mm	Unit Weight g	Mounting Options	Thru Hole mm	Thread mm (in.)	C'sink Metric (Imperial)
CR2-100	16	20	3,7	A, B, C, D, E, S	Ø3,30	M3 X 0,5 (#4-40 UNC)	90° (82°)
CR2-200	19	21	4,0				
CR2-300	23	24	4,3				
CR2-400	27	27	4,5				

Model Number Ordering Code

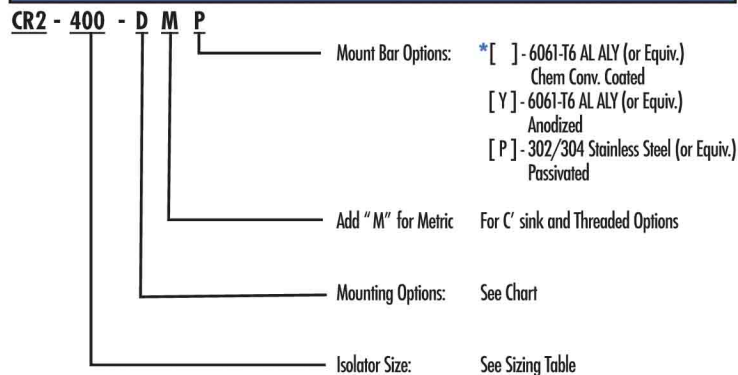

Mounting Options

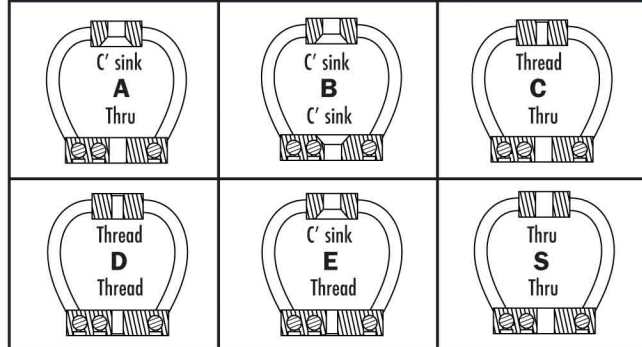

* Standard features. Any non-standard items may require longer lead times. Call for quotation.

- Maximum recommended torque for tapped aluminum bar is 1,2 Nm
- Wire Rope Material: Stranded 300 series stainless steel
- Operating Temperature Range: -100°C to 260°C
- U.S. Patent 6,290,217

Static Load vs. Deflection

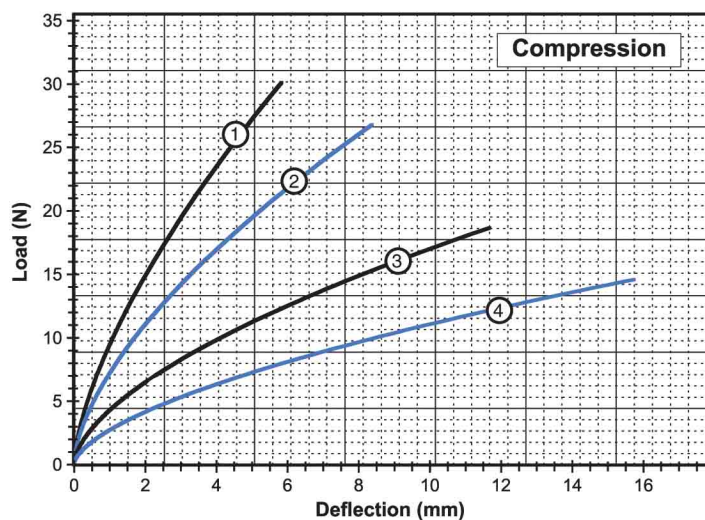

Compression

Curve	Model	Max Static Load N	Max Deflection mm	Kv (vibration) kN/m	Ks (shock) kN/m
1	CR2-100	12	5,8	11	6,1
2	CR2-200	9,3	8,4	8,8	4,0
3	CR2-300	6,7	11,7	5,3	1,9
4	CR2-400	4,9	15,7	3,5	1,2

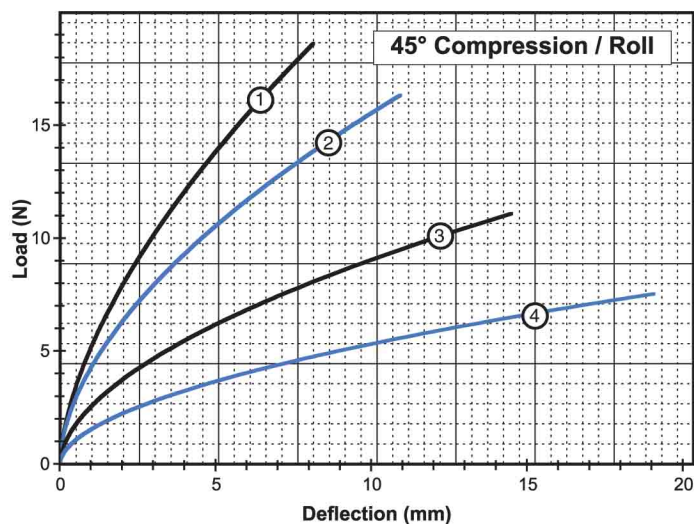

45° Compression/Roll

Curve	Model	Max Static Load N	Max Deflection mm	Kv (vibration) kN/m	Ks (shock) kN/m
1	CR2-100	5,8	8,1	6,1	2,8
2	CR2-200	4,9	10,9	5,3	1,9
3	CR2-300	3,3	14,5	3,2	1,0
4	CR2-400	2,2	19,1	1,9	0,51

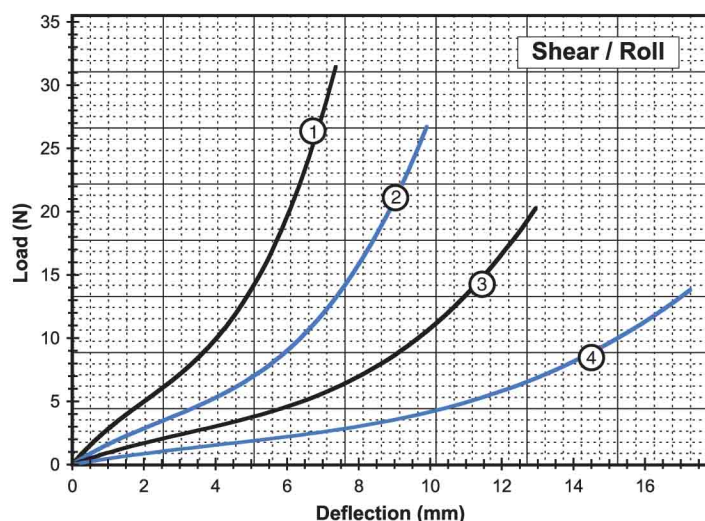

Shear/Roll

Curve	Model	Max Static Load N	Max Deflection mm	Kv (vibration) kN/m	Ks (shock) kN/m
1	CR2-100	5,6	7,4	3,0	3,0
2	CR2-200	4,0	9,9	1,8	1,8
3	CR2-300	2,9	13,0	1,1	1,1
4	CR2-400	2,0	17,3	0,53	0,53

Note: Do not extrapolate plotted curves.

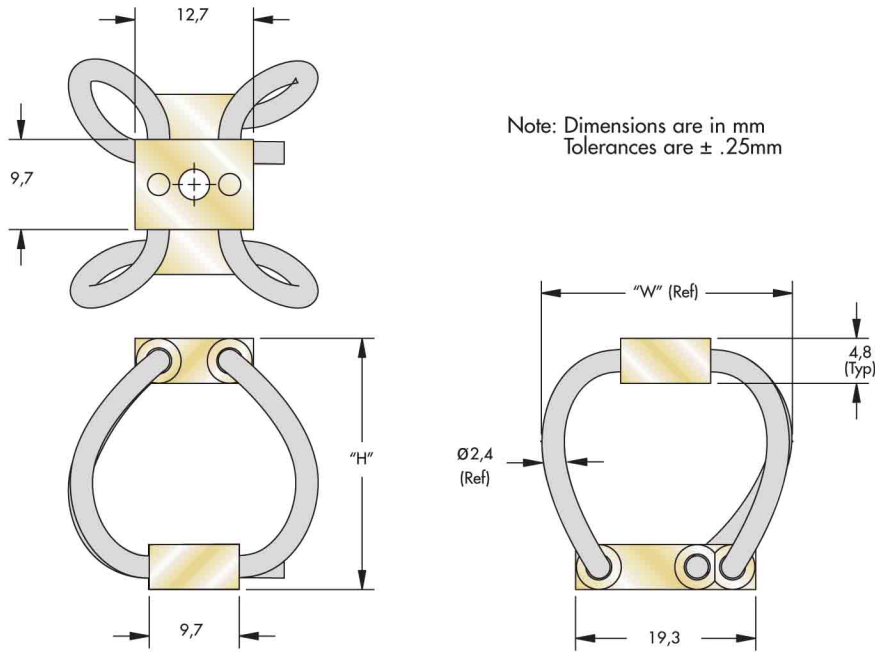

Size	Height "H" mm	Width Ref "W" mm	Unit Weight g	Mounting Options	Thru Hole mm	Thread mm (in.)	C'sink Metric (Imperial)
CR3-100	19	22	5,7	A, B, C, D, E, S	Ø3,30	M3 X 0,5 (#4-40 UNC)	90° (82°)
CR3-200	23	24	6,2				
CR3-300	27	27	6,8				
CR3-400	33	30	7,4				

Model Number Ordering Code

CR3 - 400 - D M P

- Mount Bar Options:
 - * [] - 6061-T6 AL ALY (or Equiv.) Chem Conv. Coated
 - [Y] - 6061-T6 AL ALY (or Equiv.) Anodized
 - [P] - 302/304 Stainless Steel (or Equiv.) Passivated
- Add "M" for Metric For C' sink and Threaded Options
- Mounting Options: See Chart
- Isolator Size: See Sizing Table

Mounting Options

* Standard features. Any non-standard items may require longer lead times. Call for quotation.

- Maximum recommended torque for tapped aluminum bar is 1,5 Nm
- Wire Rope Material: Stranded 300 series stainless steel
- Operating Temperature Range: -100°C to 260°C
- U.S. Patent 6,290,217

Static Load vs. Deflection

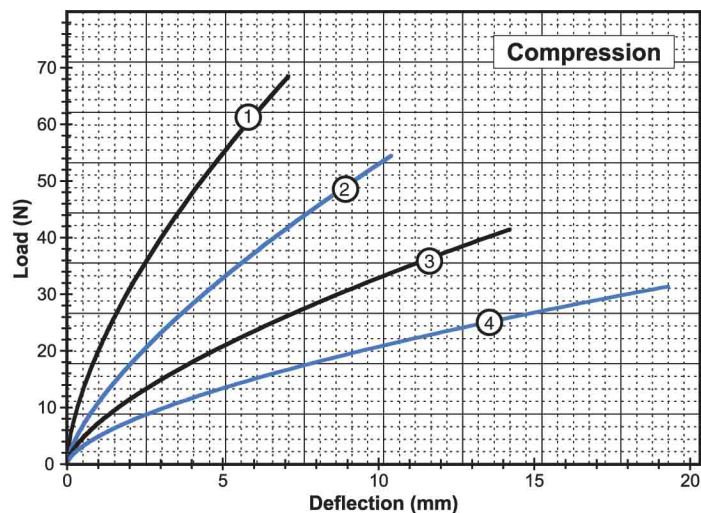

Compression

Curve	Model	Max Static Load N	Max Deflection mm	Kv (vibration) kN/m	Ks (shock) kN/m
1	CR3-100	29	7,1	24	12
2	CR3-200	22	10,4	12	6,1
3	CR3-300	18	14,2	8,4	3,5
4	CR3-400	11	19,3	5,8	1,9

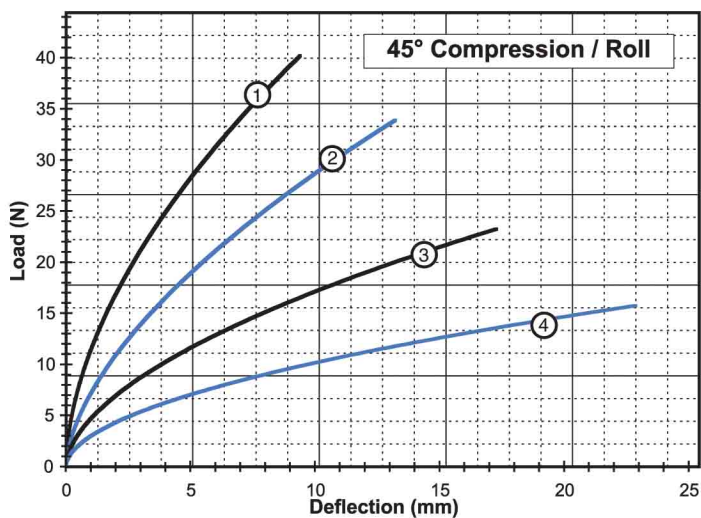

45° Compression/Roll

Curve	Model	Max Static Load N	Max Deflection mm	Kv (vibration) kN/m	Ks (shock) kN/m
1	CR3-100	12	9,4	14	5,3
2	CR3-200	10	13,2	8,8	3,2
3	CR3-300	6,7	17,3	5,8	1,8
4	CR3-400	4,4	22,9	3,5	0,91

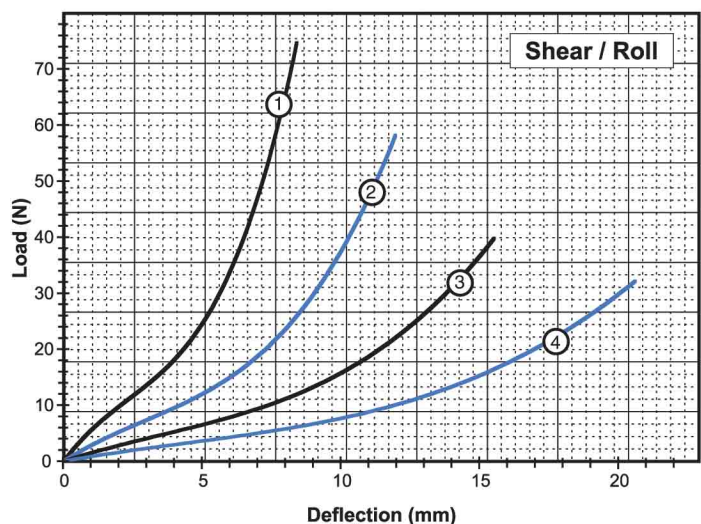

Shear/Roll

Curve	Model	Max Static Load N	Max Deflection mm	Kv (vibration) kN/m	Ks (shock) kN/m
1	CR3-100	12	8,4	6,1	6,1
2	CR3-200	8,5	11,9	3,5	3,5
3	CR3-300	6,2	15,5	1,8	1,8
4	CR3-400	4,4	20,6	1,1	1,1

Note: Do not extrapolate plotted curves.

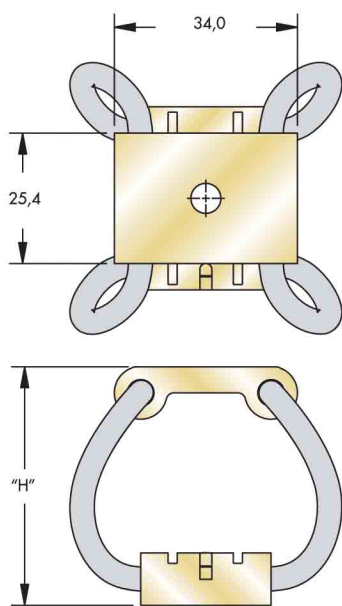

Note: Dimensions are in mm
Tolerances are ± .25mm

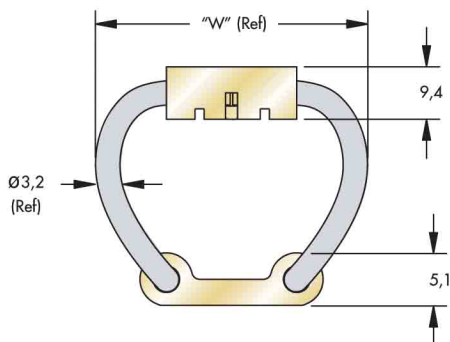

Size	Height "H" mm	Width Ref "W" mm	Unit Weight g	Mounting Options	Thru Hole mm	Thread mm (in.)	C'sink Metric (Imperial)
CR4-100	42	47	40	A, B, C, D, E, S	Ø7,00	M6 X 1,0 (#10-32 UNF)	90° (82°)
CR4-200	53	54	40				
CR4-300	60	59	43				
CR4-400	75	68	48				

Model Number Ordering Code

CR4 - 400 - D M P

- Mount Bar Options:
 - *[] - 6061-T6 AL ALY (or Equiv.) Chem Conv. Coated
 - [Y] - 6061-T6 AL ALY (or Equiv.) Anodized
 - [P] - 302/304 Stainless Steel (or Equiv.) Passivated
- Add "M" for Metric: All Mounting Options
- Mounting Options: See Chart
- Isolator Size: See Sizing Table

Mounting Options

<p>Thru</p> <p>C'sink</p>	<p>C'sink</p> <p>C'sink</p>	<p>Thru</p> <p>Thread</p>
<p>Thread</p> <p>Thread</p>	<p>Thread</p> <p>C'sink</p>	<p>Thru</p> <p>Thru</p>

* Standard features. Any non-standard items may require longer lead times. Call for quotation.

- Maximum recommended torque for tapped aluminum bar is 7,5 Nm
- Wire Rope Material: Stranded 300 series stainless steel
- Operating Temperature Range: -100°C to 260°C
- U.S. Patent 6,244,579

Static Load vs. Deflection

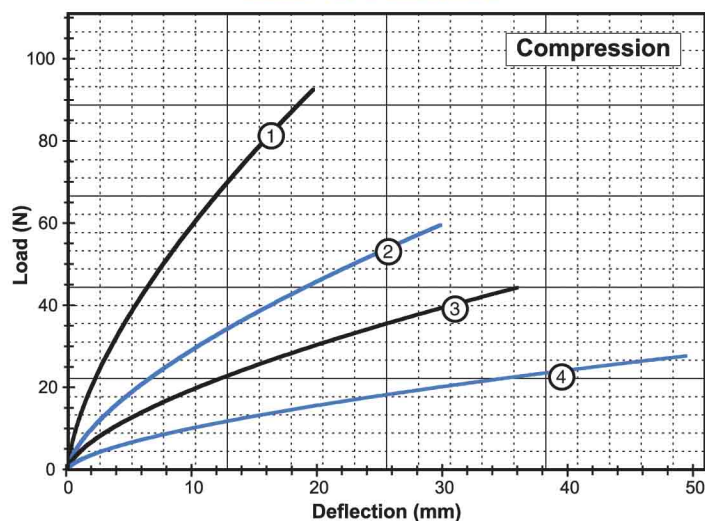

Compression

Curve	Model	Max Static Load N	Max Deflection mm	Kv (vibration) kN/m	Ks (shock) kN/m
1	CR4-100	24	19,6	12	5,8
2	CR4-200	18	29,7	6,0	2,5
3	CR4-300	13	35,8	4,4	1,6
4	CR4-400	6,7	49,3	2,2	0,70

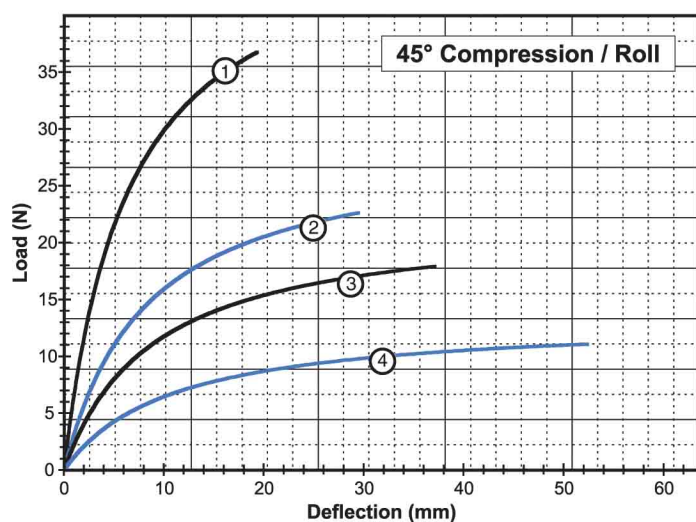

45° Compression/Roll

Curve	Model	Max Static Load N	Max Deflection mm	Kv (vibration) kN/m	Ks (shock) kN/m
1	CR4-100	11	19,3	6,4	2,8
2	CR4-200	6,7	29,5	3,1	1,1
3	CR4-300	5,3	37,1	2,2	0,70
4	CR4-400	3,6	52,3	1,1	0,35

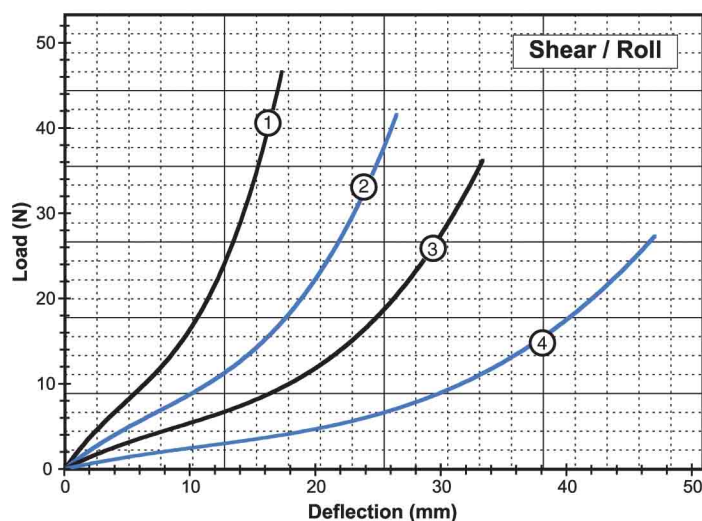

Shear/Roll

Curve	Model	Max Static Load N	Max Deflection mm	Kv (vibration) kN/m	Ks (shock) kN/m
1	CR4-100	8,5	17,3	1,9	1,9
2	CR4-200	7,1	26,4	1,1	1,1
3	CR4-300	5,3	33,3	0,70	0,70
4	CR4-400	3,3	47,0	0,35	0,35

Note: Do not extrapolate plotted curves.

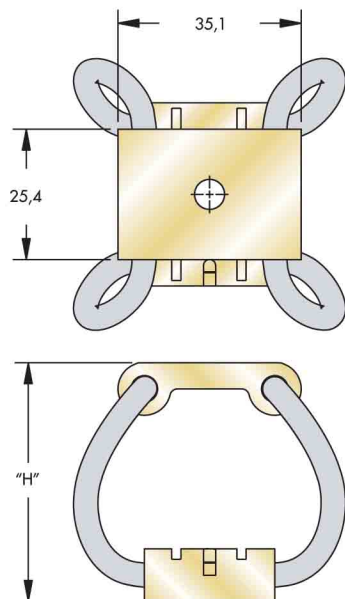

Note: Dimensions are in mm
Tolerances are ± .25mm

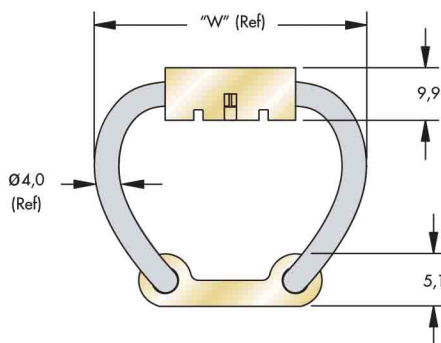

Size	Height "H" mm	Width Ref "W" mm	Unit Weight g	Mounting Options	Thru Hole mm	Thread mm (in.)	C'sink Metric (Imperial)
CR5-100	41	48	45	A, B, C, D, E, S	Ø7,00	M6 X 1,0 (#10-32 UNF)	90° (82°)
CR5-200	53	54	48				
CR5-300	60	59	51				
CR5-400	76	67	57				

Model Number Ordering Code

CR5 - 400 - D M P

- Mount Bar Options:
 - * [] - 6061-T6 AL ALY (or Equiv.) Chem Conv. Coated
 - [Y] - 6061-T6 AL ALY (or Equiv.) Anodized
 - [P] - 302/304 Stainless Steel (or Equiv.) Passivated
- Add "M" for Metric All Mounting Options
- Mounting Options: See Chart
- Isolator Size: See Sizing Table

Mounting Options

<p>Thru</p> <p>A</p> <p>C' sink</p>	<p>C' sink</p> <p>B</p> <p>C' sink</p>	<p>Thru</p> <p>C</p> <p>Thread</p>
<p>Thread</p> <p>D</p> <p>Thread</p>	<p>Thread</p> <p>E</p> <p>C' sink</p>	<p>Thru</p> <p>S</p> <p>Thru</p>

* Standard features. Any non-standard items may require longer lead times. Call for quotation.

- Maximum recommended torque for tapped aluminum bar is 7,5 Nm
- Wire Rope Material: Stranded 300 series stainless steel
- Operating Temperature Range: -100°C to 260°C
- U.S. Patent 6,244,579

Static Load vs. Deflection

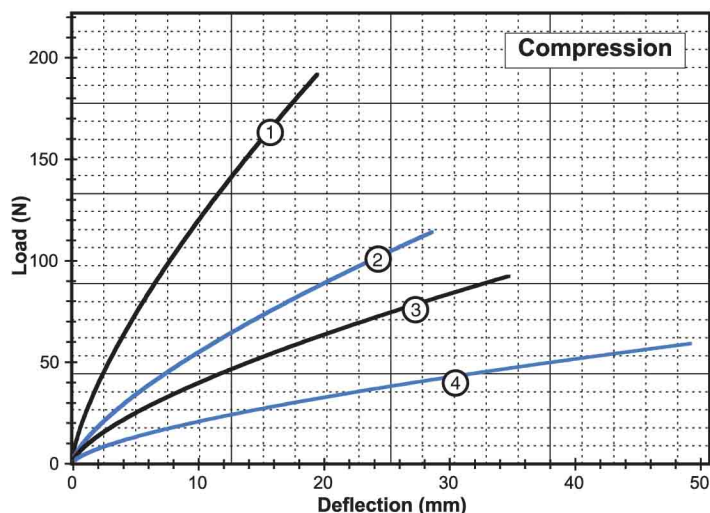

Compression

Curve	Model	Max Static Load N	Max Deflection mm	Kv (vibration) kN/m	Ks (shock) kN/m
1	CR5-100	80	19,6	22	11
2	CR5-200	38	28,7	11	4,4
3	CR5-300	27	34,8	7,9	3,2
4	CR5-400	16	49,3	4,4	1,4

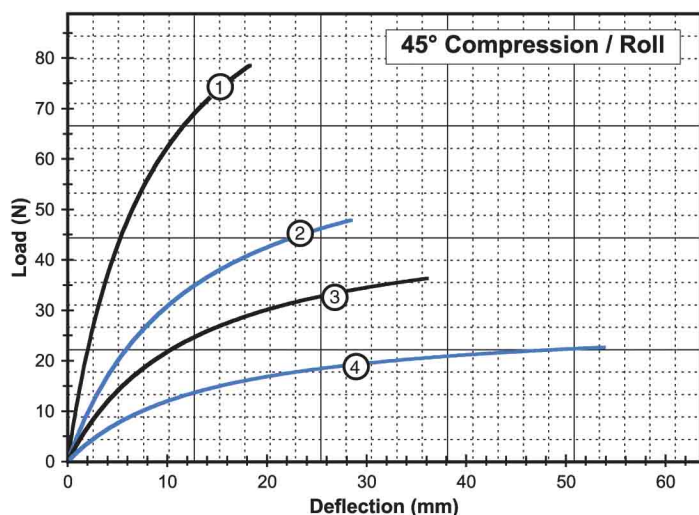

45° Compression/Roll

Curve	Model	Max Static Load N	Max Deflection mm	Kv (vibration) kN/m	Ks (shock) kN/m
1	CR5-100	24	18,3	12	6,1
2	CR5-200	13	28,4	5,3	2,3
3	CR5-300	11	36,1	3,6	1,4
4	CR5-400	6,7	53,8	1,9	0,70

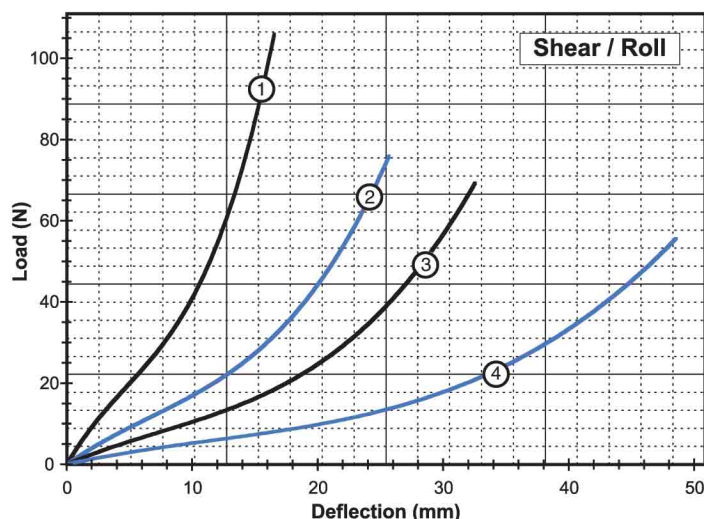

Shear/Roll

Curve	Model	Max Static Load N	Max Deflection mm	Kv (vibration) kN/m	Ks (shock) kN/m
1	CR5-100	20	16,5	25 4,4	4,4
2	CR5-200	13	25,7	12 2,1	2,1
3	CR5-300	11	32,5	8 1,4	1,4
4	CR5-400	6,7	48,5	0,70	0,70

Note: Do not extrapolate plotted curves.

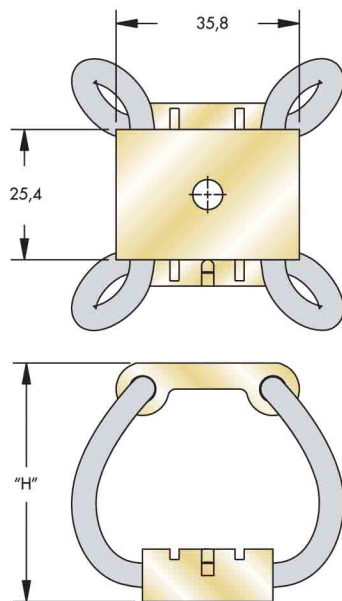

Note: Dimensions are in mm
Tolerances are ± .25mm

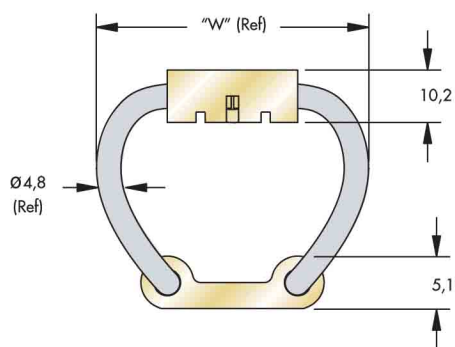

Size	Height "H" mm	Width Ref "W" mm	Unit Weight g	Mounting Options	Thru Hole mm	Thread mm (in.)	C'sink Metric (Imperial)
CR6-100	47	54	57	A, B, C, D, E, S	Ø7,00	M6 X 1,0 (#10-32 UNF)	90° (82°)
CR6-200	55	59	62				
CR6-300	64	64	65				
CR6-400	79	73	74				

Model Number Ordering Code

CR6 - 400 - D M P

- Mount Bar Options:
 - [] - 6061-T6 AL ALY (or Equiv.) Chem Conv. Coated
 - [Y] - 6061-T6 AL ALY (or Equiv.) Anodized
 - [P] - 302/304 Stainless Steel (or Equiv.) Passivated
- Add "M" for Metric: All Mounting Options
- Mounting Options: See Chart
- Isolator Size: See Sizing Table

Mounting Options

<p>Thru</p> <p>A</p> <p>C'sink</p>	<p>C'sink</p> <p>B</p> <p>C'sink</p>	<p>Thru</p> <p>C</p> <p>Thread</p>
<p>Thread</p> <p>D</p> <p>Thread</p>	<p>Thread</p> <p>E</p> <p>C'sink</p>	<p>Thru</p> <p>S</p> <p>Thru</p>

* Standard features. Any non-standard items may require longer lead times. Call for quotation.

- Maximum recommended torque for topped aluminum bar is 7,5 Nm
- Wire Rope Material: Stranded 300 series stainless steel
- Operating Temperature Range: -100°C to 260°C
- U.S. Patent 6,244,579

Static Load vs. Deflection

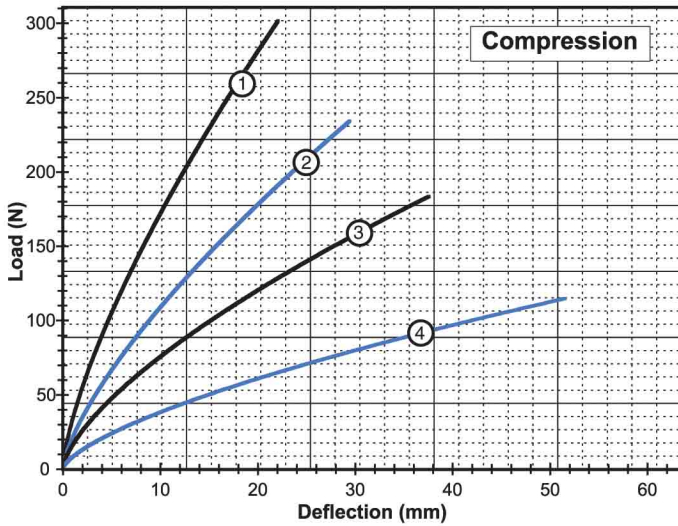

Compression

Curve	Model	Max Static Load N	Max Deflection mm	Kv (vibration) kN/m	Ks (shock) kN/m
1	CR6-100	142	22,1	32	16
2	CR6-200	93	29,5	20	9,6
3	CR6-300	67	37,6	15	5,3
4	CR6-400	36	51,6	7,9	2,6

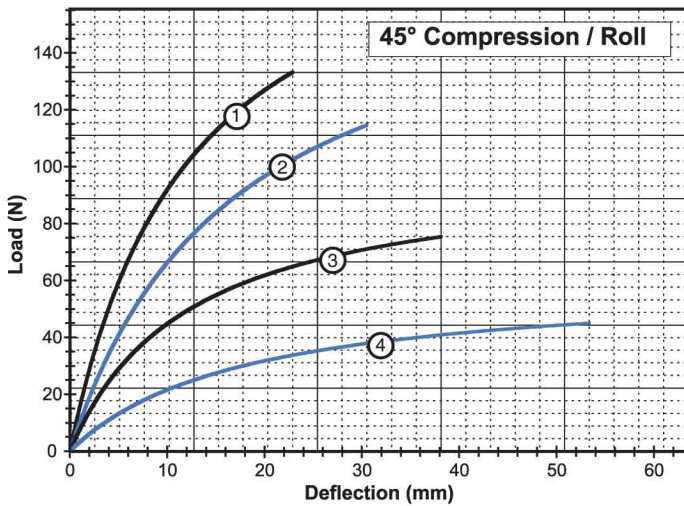

45° Compression/Roll

Curve	Model	Max Static Load N	Max Deflection mm	Kv (vibration) kN/m	Ks (shock) kN/m
1	CR6-100	40	22,9	16	7,9
2	CR6-200	33	30,5	9,6	5,3
3	CR6-300	22	38,1	7,9	2,8
4	CR6-400	13	53,3	3,5	1,2

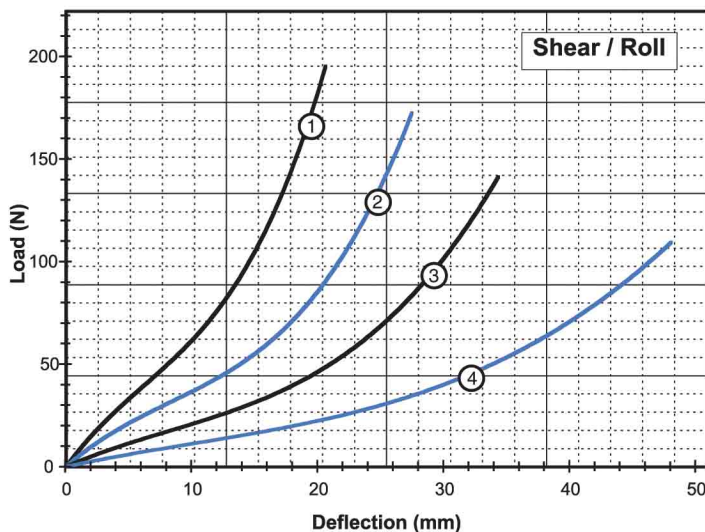

Shear/Roll

Curve	Model	Max Static Load N	Max Deflection mm	Kv (vibration) kN/m	Ks (shock) kN/m
1	CR6-100	40	20,6	7,9	7,9
2	CR6-200	31	27,4	4,4	4,4
3	CR6-300	22	34,3	2,6	2,6
4	CR6-400	16	48,0	1,6	1,6

Note: Do not extrapolate plotted curves.

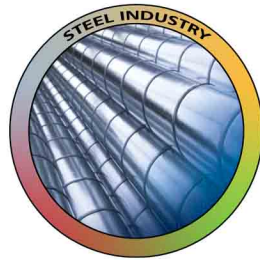
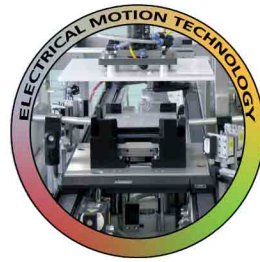

we look forward to your application.

LDA Belgium

Hoge Buizen 53
1980 Eppegem
Belgium

Tel. +32(0)2-266 13 13
Mail: LDA@LDA.be

www.LDA.be