

# AIRSTROKE™

ACTUATORS

# AIRMOUNT™

ISOLATORS

## METRIC SINGLE CONVOLUTION

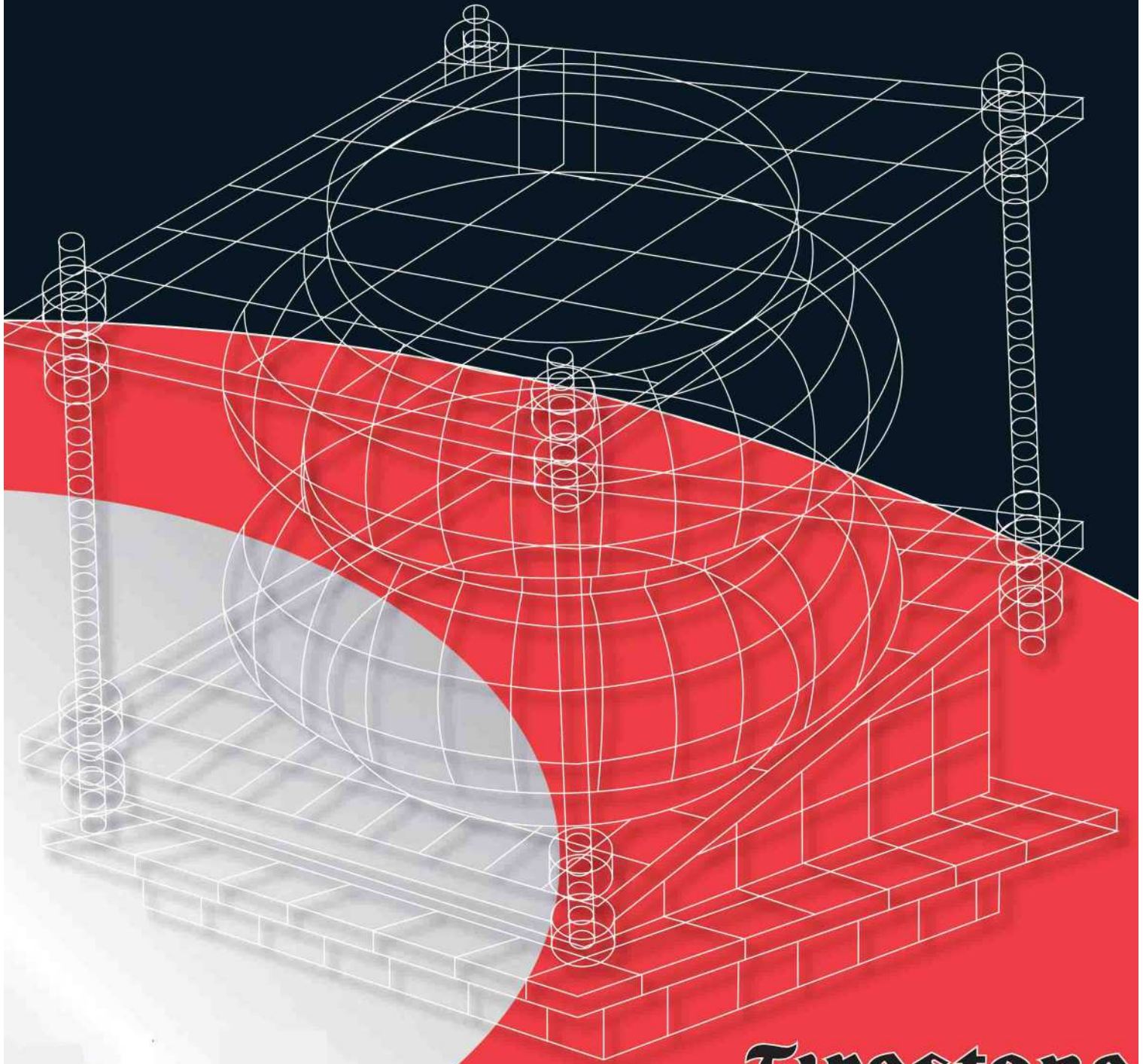

# Firestone

World's Number 1  
Air Spring.



FIRESTONE INDUSTRIAL PRODUCTS COMPANY

**NOTE: All Assembly Order Numbers are for bead plate parts unless noted otherwise.**

	Description	Assembly Order No.
Style 16	Blind nuts, 1/4 BSP	W01-M58-6140
	Socket head aluminum bead rings (bolts, nuts, washers not included—use M6 cap screws)	W01-358-0017
Two Ply Bellows	Rubber bellows only	W01-358-0010
Assembly weight.....		1.13 kg.
Force to collapse to minimum height (@ 0 BAR)		133 N.

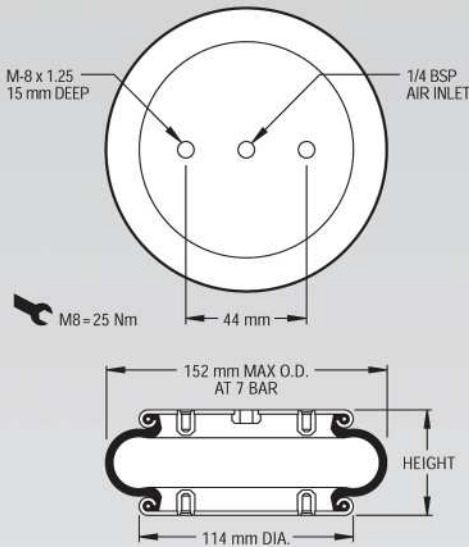

**NOTE: A bead plate part is shown. This part is also available with bead rings. Bolts are not included. See pages 8-10 for explanation.**

Gauge Pressure (BAR)	Load (kN)	Spring Rate (kN/m)	Natural Frequency Hz
3	2.04	140	4.13
4	2.76	177	3.99
5	3.52	217	3.91
6	4.36	256	3.82
7	5.10	293	3.78

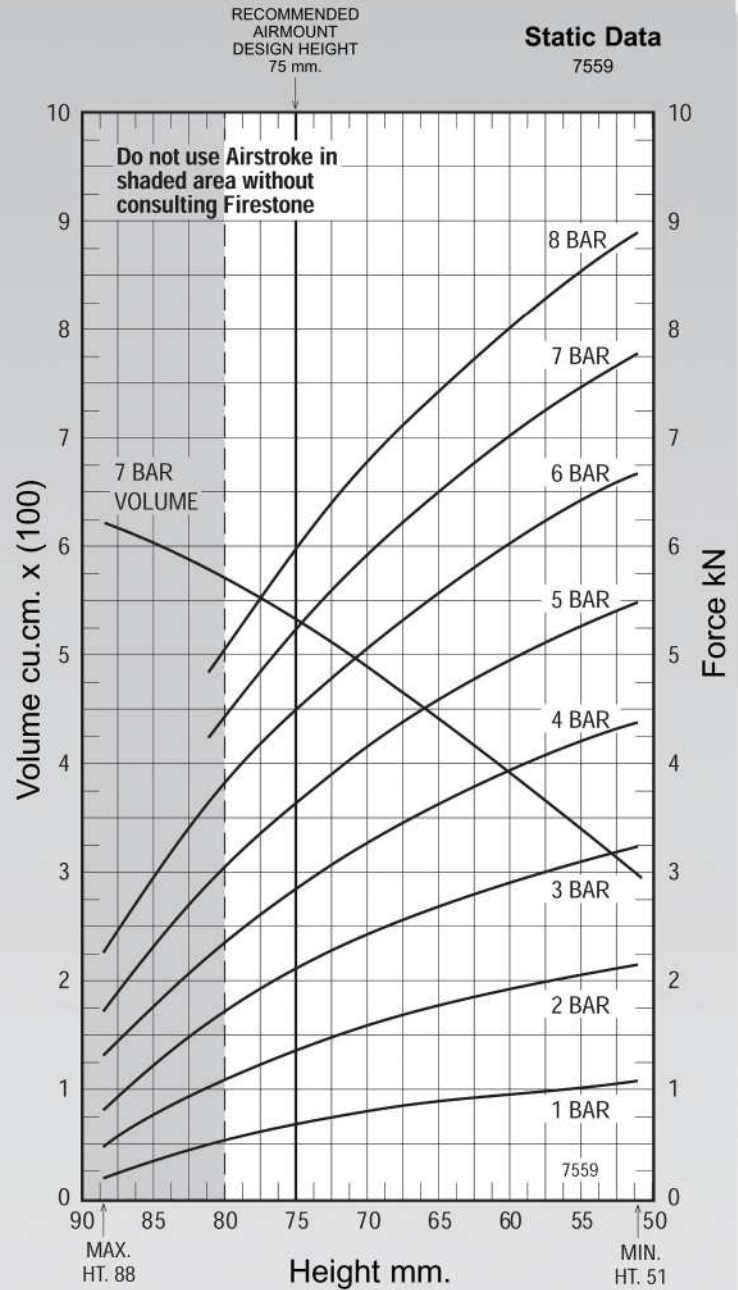

See page 12 for instructions on how to use chart.

Assembly Height (mm)	Volume @ 7 BAR (cu cm)	EFF Area @ 7 BAR (cm**2)	kN Force				
			@ 3 BAR	@ 4 BAR	@ 5 BAR	@ 6 BAR	@ 7 BAR
80	575	61	1.61	2.25	2.89	3.62	4.26
70	492	83	2.37	3.20	4.06	4.98	5.81
60	390	99	2.85	3.88	4.89	5.95	6.93

RECOMMENDED  
AIRMOUNT  
DESIGN HEIGHT  
75 mm.

**Static Data**  
B4165

	Description	Assembly Order No.
Style 16-ST	Blind nuts, 1/4 BSP	W02-M58-5001
	Stainless steel plates	W02-M58-5003
Two Ply Bellows		
Assembly weight.....		0.58 kg.
Force to collapse to minimum height (@ 0 BAR)		35.5 N.

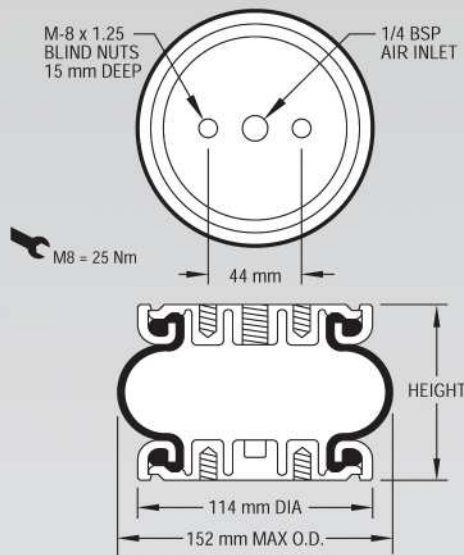

**NOTE:** The bellows extends beyond the bead plates at minimum height.

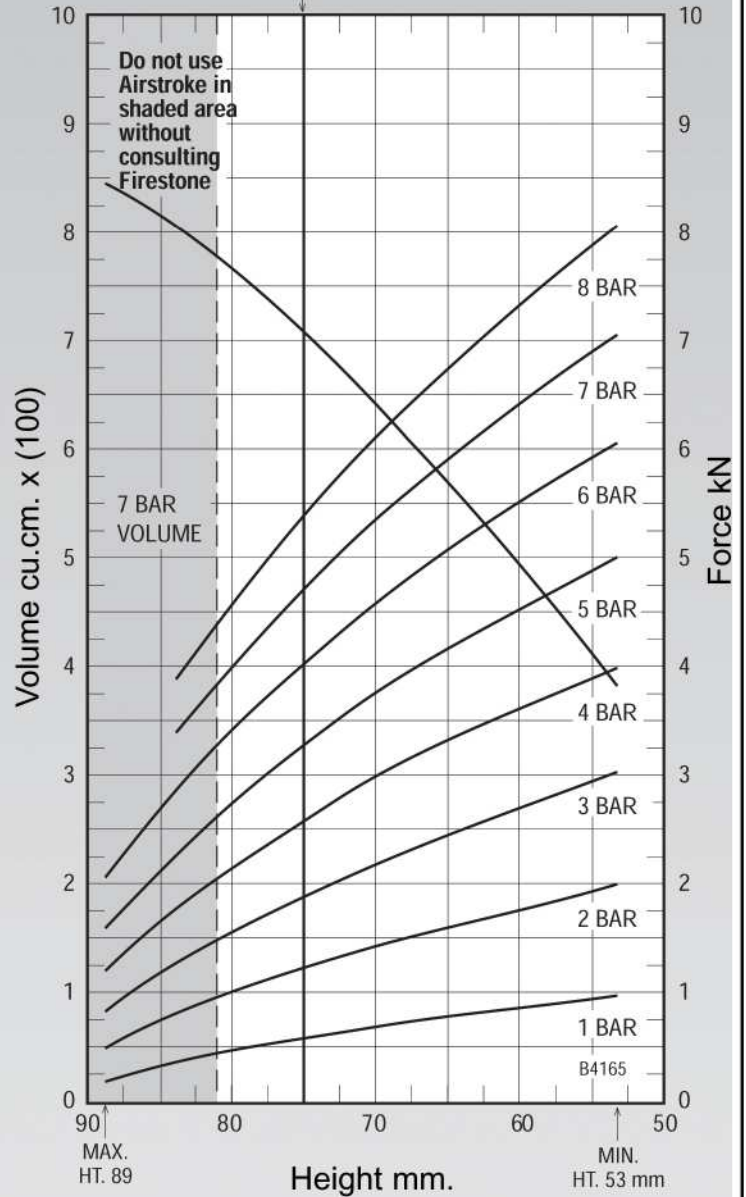

See page 12 for instructions on how to use chart.

Dynamic Characteristics at 75 mm Design Height (Required for Airmount isolator design only)			
Gauge Pressure (BAR)	Load (kN)	Spring Rate (kN/m)	Natural Frequency Hz
3	1.85	132.58	4.22
4	2.53	171.56	4.11
5	3.2	209.02	4.07
6	3.94	246.21	3.94
7	4.59	281.12	3.9

Force Table (Use for Airstroke™ actuator design)							
Assembly Height (mm)	Volume @ 7 BAR (cu cm)	EFF Area @ 7 BAR (cm**2)	kN Force				
			@ 3 BAR	@ 4 BAR	@ 5 BAR	@ 6 BAR	@ 7 BAR
80	460	55.24	1.52	2.07	2.64	3.29	3.87
75	426	65.63	1.85	2.53	3.20	3.94	4.59
70	386	75.10	2.14	2.93	3.69	4.51	5.26
65	343	83.28	2.42	3.27	4.11	5.00	5.83
60	303	90.11	2.67	3.56	4.46	5.42	6.31
55	256	97.34	2.92	3.86	4.83	5.86	6.81

**NOTE: All Assembly Order Numbers are for bead plate parts unless noted otherwise.**

	Description	Assembly Order No.
Style 131	Blind nuts, 1/4 BSP	W01-M58-6155
	Socket head aluminum bead rings (bolts, nuts, washers not included—use M6 cap screws)	W01-358-0127
Two Ply Bellows	Rubber bellows only	W01-358-0131
Assembly weight.....		71.1 kg.
Force to collapse to minimum height (@ 0 BAR)		142 N.

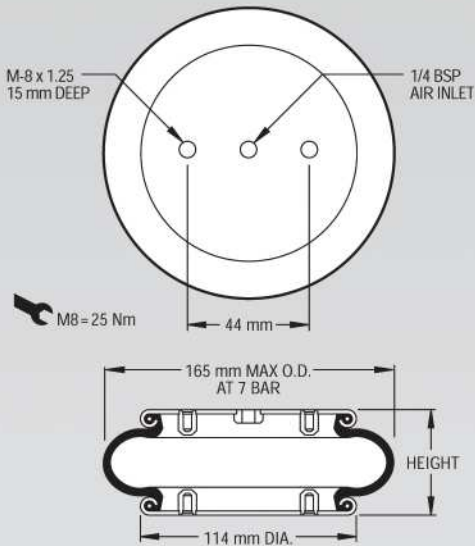

**NOTE: A bead plate part is shown. This part is also available with bead rings. Bolts are not included. See pages 8-10 for explanation.**

Dynamic Characteristics at 90 mm Design Height (Required for Airmount isolator design only)			
Gauge Pressure (BAR)	Load (kN)	Spring Rate (kN/m)	Natural Frequency Hz
3	2.50	103	3.20
4	3.51	133	3.07
5	4.48	162	3.00
6	5.57	193	2.93
7	6.54	221	2.90

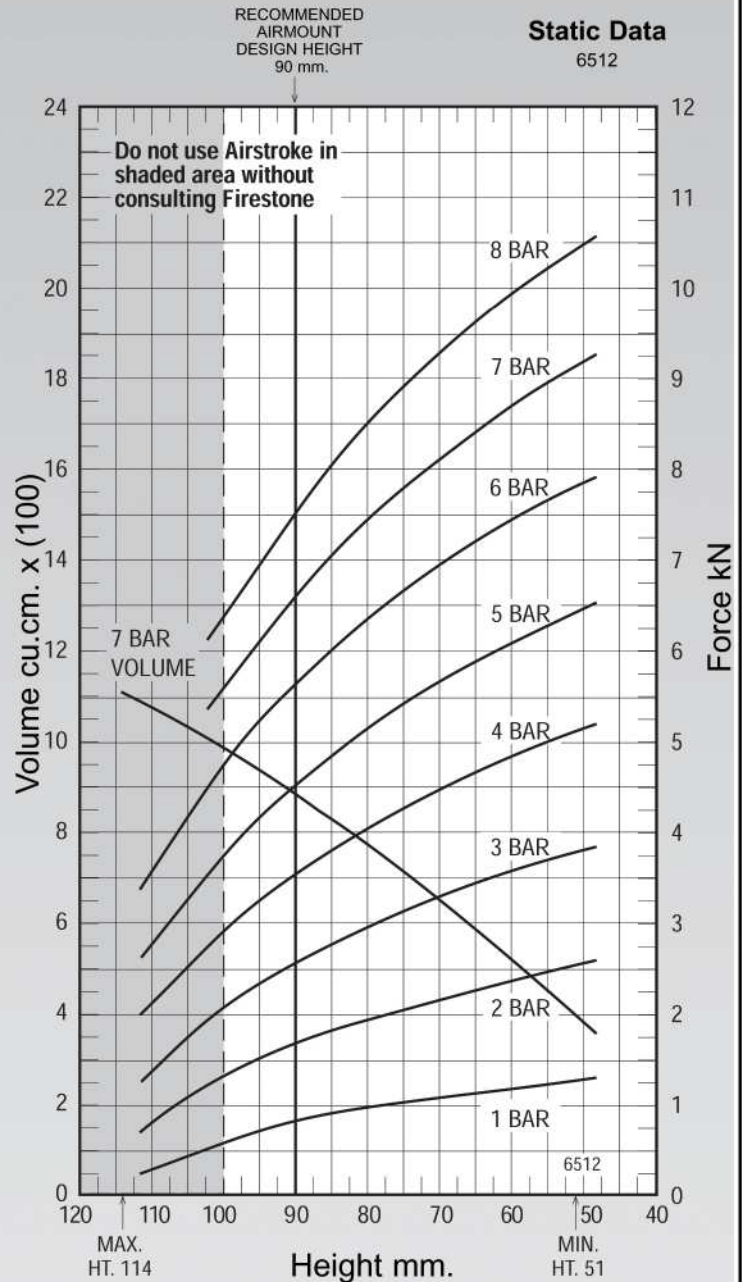

See page 12 for instructions on how to use chart.

Force Table (Use for Airstroke™ actuator design)							
Assembly Height (mm)	Volume @ 7 BAR (cu cm)	EFF Area @ 7 BAR (cm**2)	kN Force				
			@ 3 BAR	@ 4 BAR	@ 5 BAR	@ 6 BAR	@ 7 BAR
100	982	78	1.96	2.83	3.65	4.63	5.48
90	880	93	2.50	3.51	4.48	5.57	6.54
80	774	105	2.90	4.01	5.10	6.30	7.38
70	652	115	3.23	4.44	5.61	6.91	8.08
60	529	124	3.51	4.79	6.05	7.41	8.65

**NOTE: All Assembly Order Numbers are for bead plate parts unless noted otherwise.**

	Description	Assembly Order No.
Style 110	Blind nuts, 1/4 BSP	W01-M58-6145
	Socket head aluminum bead rings (bolts, nuts, washers not included—use M6 cap screws)	W01-358-0112
Two Ply Bellows	Rubber bellows only	W01-358-0100
Assembly weight.....		1.36 kg.
Force to collapse to minimum height (@ 0 BAR)		36 N.

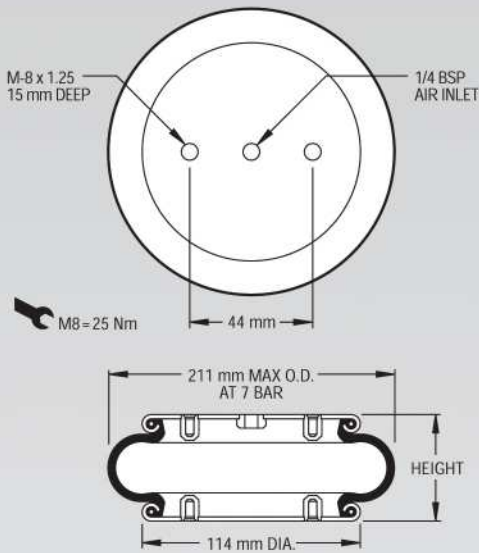

**NOTE: A bead plate part is shown. This part is also available with bead rings. Bolts are not included. See pages 8-10 for explanation.**

RECOMMENDED AIRMOUNT DESIGN HEIGHT 115 mm.

**Static Data**  
9258

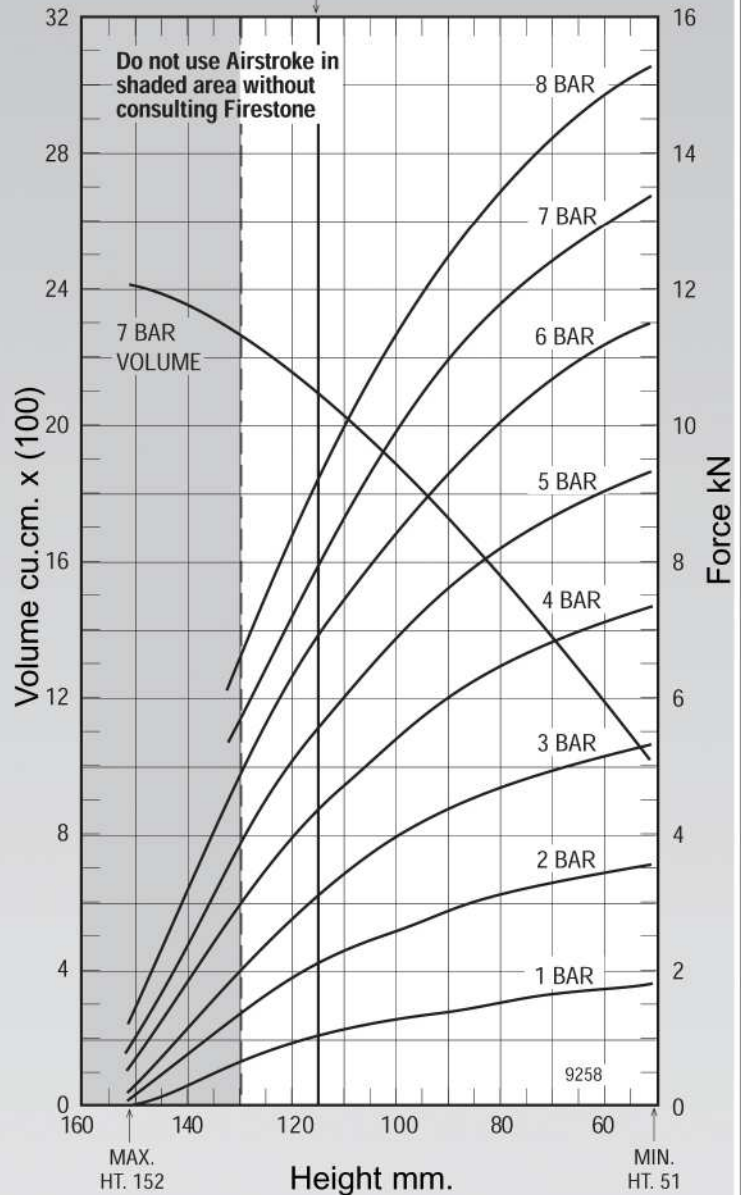

See page 12 for instructions on how to use chart.

Dynamic Characteristics at 115 mm Design Height (Required for Airmount isolator design only)			
Gauge Pressure (BAR)	Load (kN)	Spring Rate (kN/m)	Natural Frequency Hz
3	3.10	99	2.82
4	4.29	127	2.72
5	5.48	157	2.67
6	6.78	189	2.63
7	7.92	218	2.62

Force Table (Use for Airstroke™ actuator design)							
Assembly Height (mm)	Volume @ 7 BAR (cu cm)	EFF Area @ 7 BAR (cm**2)	kN Force				
			@ 3 BAR	@ 4 BAR	@ 5 BAR	@ 6 BAR	@ 7 BAR
130	2268	80	2.03	2.90	3.75	4.74	5.58
120	2167	103	2.76	3.86	4.95	6.14	7.18
110	2037	123	3.41	4.68	5.96	7.36	8.61
100	1898	140	3.92	5.34	6.78	8.36	9.78
90	1733	154	4.33	5.92	7.49	9.23	10.80
80	1568	166	4.64	6.39	8.08	9.94	11.62
70	1379	176	4.89	6.77	8.58	10.55	12.30
60	1198	184	5.09	7.05	8.97	11.03	12.85

**NOTE: All Assembly Order Numbers are for bead plate parts unless noted otherwise.**

	Description	Assembly Order No.
Style 116	Blind nuts, 1/4 BSP	W01-M58-6166
	Blind nuts, 3/4 BSP	W01-M58-6165
Two Ply Bellows	Countersunk steel bead rings, 40 mm bolts, nuts & washers	SEE NOTE BELOW
	Rubber bellows only	W01-358-0133
Assembly weight.....		1.95 kg.
Force to collapse to minimum height (@ 0 BAR)		36 N.

Style	Description	Assembly Order No.
117	Blind nuts, 1/4 BSP	W01-M58-6176
	Blind nuts, 3/4 BSP	W01-M58-6175
High Strength Construction	Countersunk steel bead rings, 40 mm bolts, nuts & washers	SEE NOTE BELOW

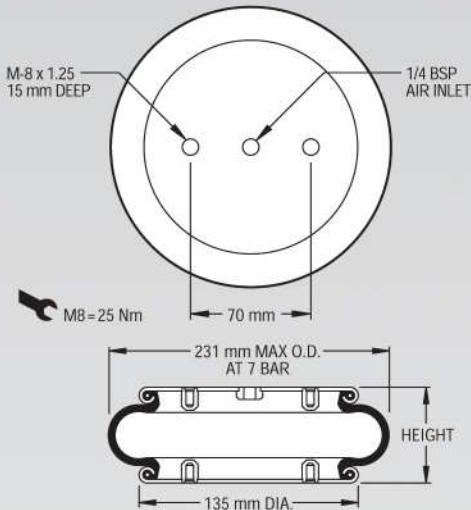

**NOTE: A bead plate part is shown. This part is also available with bead rings. See pages 8-10 for explanation.**

Dynamic Characteristics at 115 mm Design Height (Required for Airmount isolator design only)			
Gauge Pressure (BAR)	Load (kN)	Spring Rate (kN/m)	Natural Frequency Hz
3	4.16	132	2.80
4	5.73	169	2.71
5	7.26	207	2.67
6	8.98	247	2.62
7	10.55	285	2.59

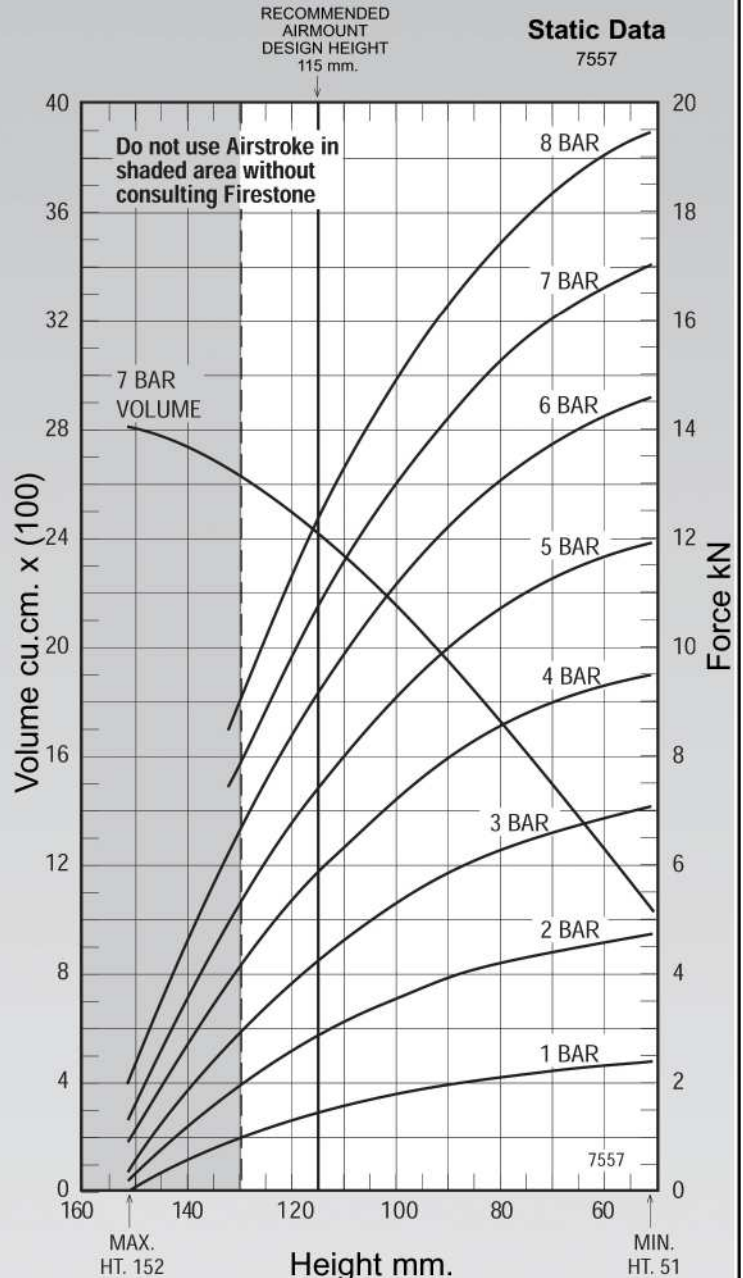

See page 12 for instructions on how to use chart.

Force Table (Use for Airstroke™ actuator design)							
Assembly Height (mm)	Volume @ 7 BAR (cu cm)	EFF Area @ 7 BAR (cm**2)	kN Force				
			@ 3 BAR	@ 4 BAR	@ 5 BAR	@ 6 BAR	@ 7 BAR
130	2635	110	2.86	4.04	5.17	6.51	7.71
120	2506	138	3.75	5.20	6.60	8.20	9.65
110	2341	163	4.54	6.22	7.86	9.70	11.38
100	2164	183	5.20	7.07	8.92	10.95	12.82
90	1956	201	5.75	7.84	9.84	12.04	14.07
80	1745	215	6.19	8.45	10.59	12.91	15.08
70	1509	228	6.54	8.91	11.18	13.64	15.92
60	1280	236	6.82	9.20	11.58	14.17	16.55

**NOTE: All Assembly Order Numbers are for bead plate parts unless noted otherwise.**

RECOMMENDED  
AIRMOUNT  
DESIGN HEIGHT  
140 mm.

**Static Data**  
8776

	Description	Assembly Order No.
Style 116-1	Blind nuts, 1/4 BSP	W01-M58-6171
Two Ply Bellows		
Assembly weight.....		2.04 kg.
Force to collapse to minimum height (@ 0 BAR)		165 N.

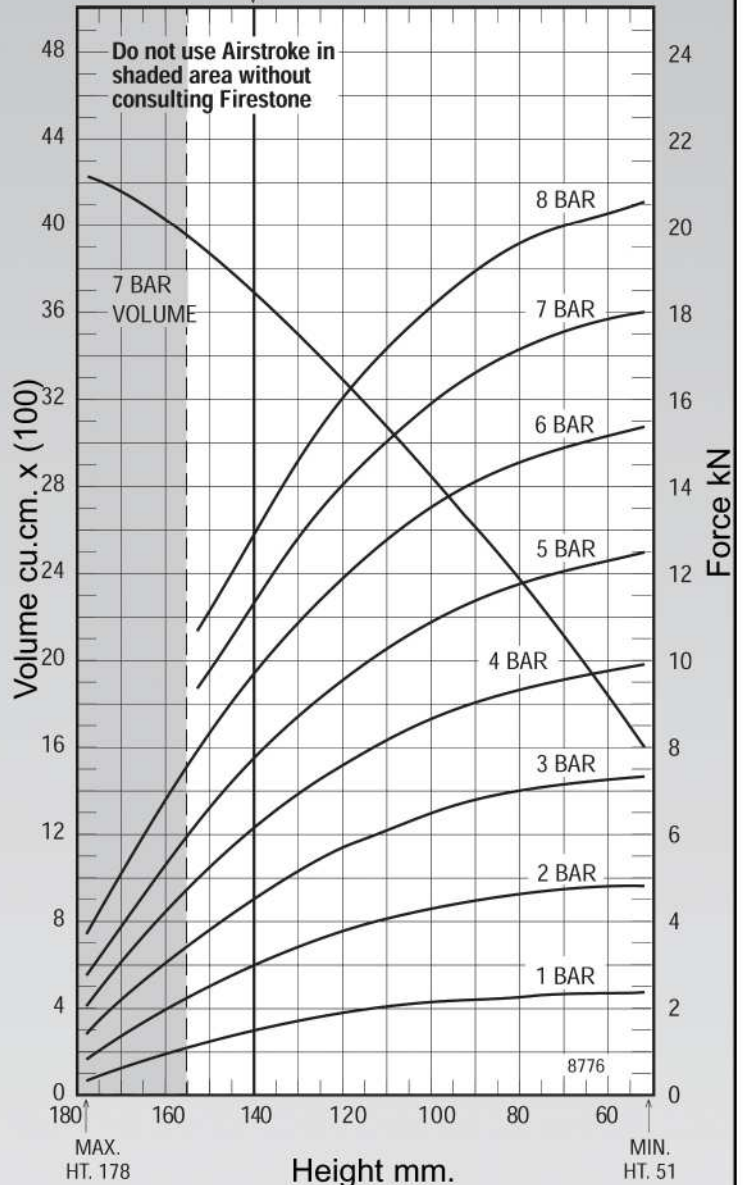
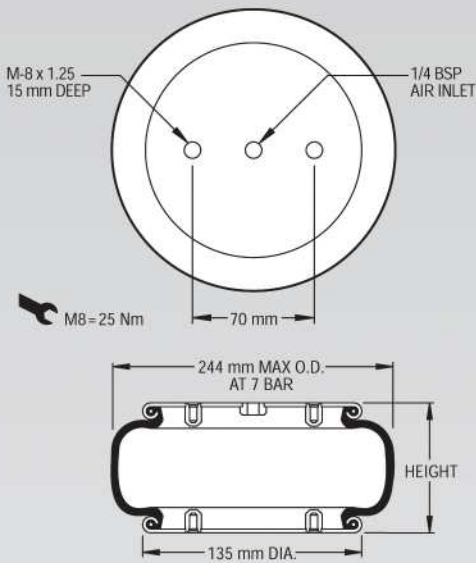

**NOTE: A bead plate part is shown. This part is also available with bead rings. See pages 8-10 for explanation.**

See page 12 for instructions on how to use chart.

Dynamic Characteristics at 140 mm Design Height (Required for Airmount isolator design only)			
Gauge Pressure (BAR)	Load (kN)	Spring Rate (kN/m)	Natural Frequency Hz
3	4.45	108	2.46
4	5.94	138	2.41
5	7.52	170	2.37
6	9.42	205	2.33
7	11.18	237	2.30

Force Table (Use for Airstroke™ actuator design)							
Assembly Height (mm)	Volume @ 7 BAR (cu cm)	EFF Area @ 7 BAR (cm**2)	kN Force				
			@ 3 BAR	@ 4 BAR	@ 5 BAR	@6 BAR	@7 BAR
140	3678	160	4.45	5.94	7.52	9.42	11.18
130	3491	180	5.08	6.77	8.55	10.66	12.61
120	3301	197	5.61	7.47	9.42	11.71	13.82
110	3085	213	6.07	8.06	10.18	12.63	14.89
100	2869	225	6.44	8.54	10.79	13.38	15.75
90	2628	236	6.76	8.94	11.31	14.02	16.49
80	2391	244	7.00	9.25	11.72	14.51	17.05
70	2130	250	7.19	9.51	12.05	14.91	17.50

**NOTE: All Assembly Order Numbers are for bead plate parts unless noted otherwise.**

	Description	Assembly Order No.
Style 115	Blind nuts, 1/4 BSP	W01-M58-6375
	Blind nuts, 1/4 BSP rubber bumper	W01-M58-6376
Two Ply Bellows	Blind nuts, 3/4 BSP	W01-M58-6374
	Countersunk steel bead rings, 40 mm bolts, nuts, washers	W01-M58-6977
	Rubber bellows only	W01-358-0118

Assembly weight.....2.49 kg.  
 Force to collapse to minimum height (@ 0 BAR) 36 N.

Style	Description	Assembly Order No.
124	Blind nuts, 1/4 BSP	W01-M58-6181
High Strength Construction	Blind nuts, 3/4 BSP	W01-M58-6182

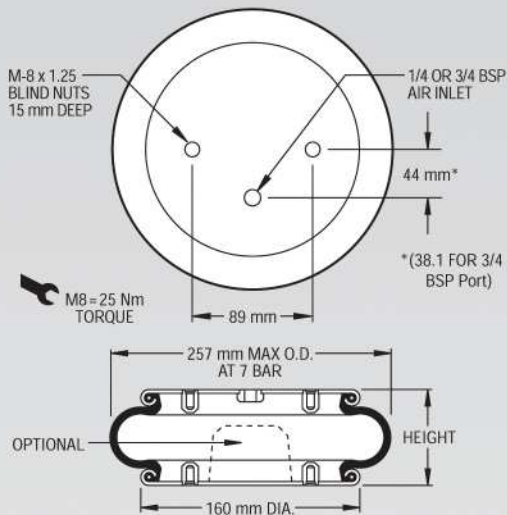

**NOTE: A bead plate part is shown. This part is also available with bead rings. See pages 8-10 for explanation.**

RECOMMENDED  
AIRMOUNT  
DESIGN HEIGHT  
115 mm.

**Static Data**  
1115

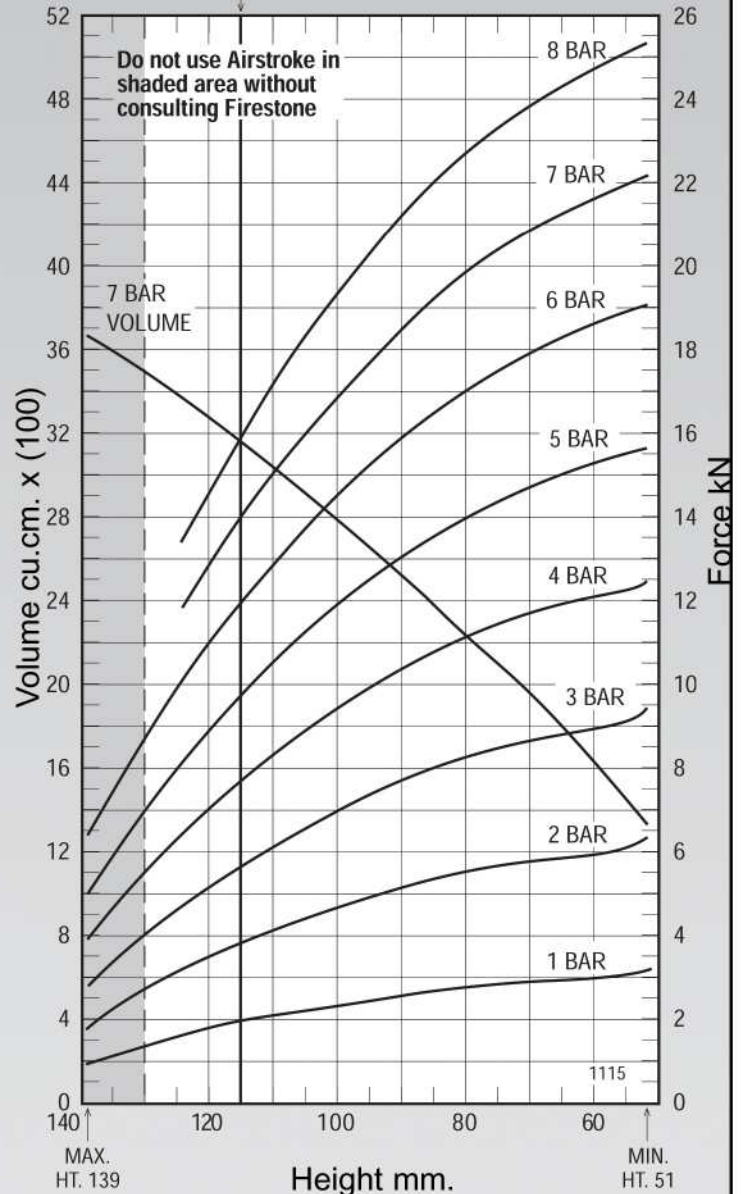

See page 12 for instructions on how to use chart.

**Dynamic Characteristics at 115mm Design Height**  
(Required for Airmount isolator design only)

Gauge Pressure (BAR)	Load (kN)	Spring Rate (kN/m)	Natural Frequency Hz
3	5.64	175	2.78
4	7.63	229	2.73
5	9.62	282	2.70
6	11.81	336	2.66
7	13.81	385	2.63

**Force Table (Use for Airstroke™ actuator design)**

Assembly Height (mm)	Volume @ 7 BAR (cu cm)	EFF Area @ 7 BAR (cm sq)	kN Force				
			@ 3 BAR	@ 4 BAR	@ 5 BAR	@ 6 BAR	@ 7 BAR
130	3467	144	3.95	5.37	6.81	8.51	10.05
120	3265	180	5.13	6.93	8.75	10.78	12.63
110	3030	213	6.11	8.25	10.40	12.74	14.88
100	2794	239	6.92	9.33	11.74	14.34	16.73
90	2525	263	7.66	10.30	12.93	15.75	18.37
80	2256	282	8.24	11.08	13.89	16.91	19.70
70	1951	297	8.62	11.65	14.64	17.82	20.76
60	1650	307	8.88	12.01	15.14	18.46	21.49



**NOTE: All Assembly Order Numbers are for bead plate parts unless noted otherwise.**

	Description	Assembly Order No.
Style 19	Blind nuts, 1/4 BSP	W01-M58-6008
	Blind nuts, 1/4 BSP, bumper	W01-M58-6373
Two Ply	Blind nuts, 3/4 BSP	W01-M58-6011
	Blind nuts, 3/4 BSP, bumper	W01-M58-6372
Bellows	Countersunk steel bead rings, 40 mm bolts, nuts, washers	W01-M58-6975
	Rubber bellows only	W01-358-0134
Assembly weight (bead plate version, no bumper)		4.45 kg.
Force to collapse to minimum height (@ 0 BAR)		40 N.

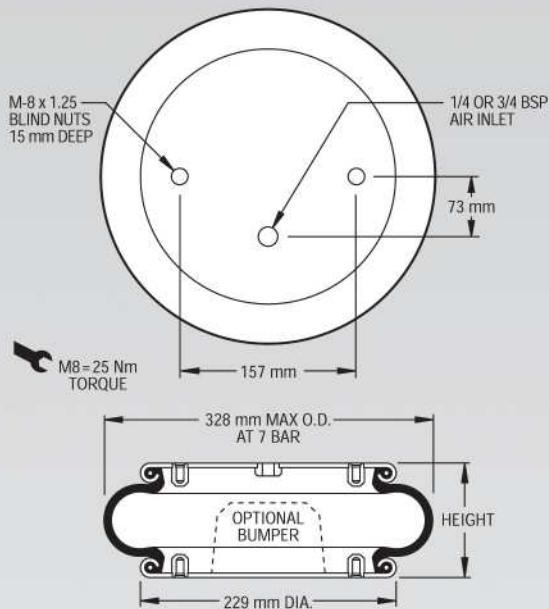

**NOTE: A bead plate part is shown. This part is also available with bead rings. See pages 8-10 for explanation.**

RECOMMENDED  
AIRMOUNT  
DESIGN HEIGHT  
125 mm.

**Static Data**  
9261

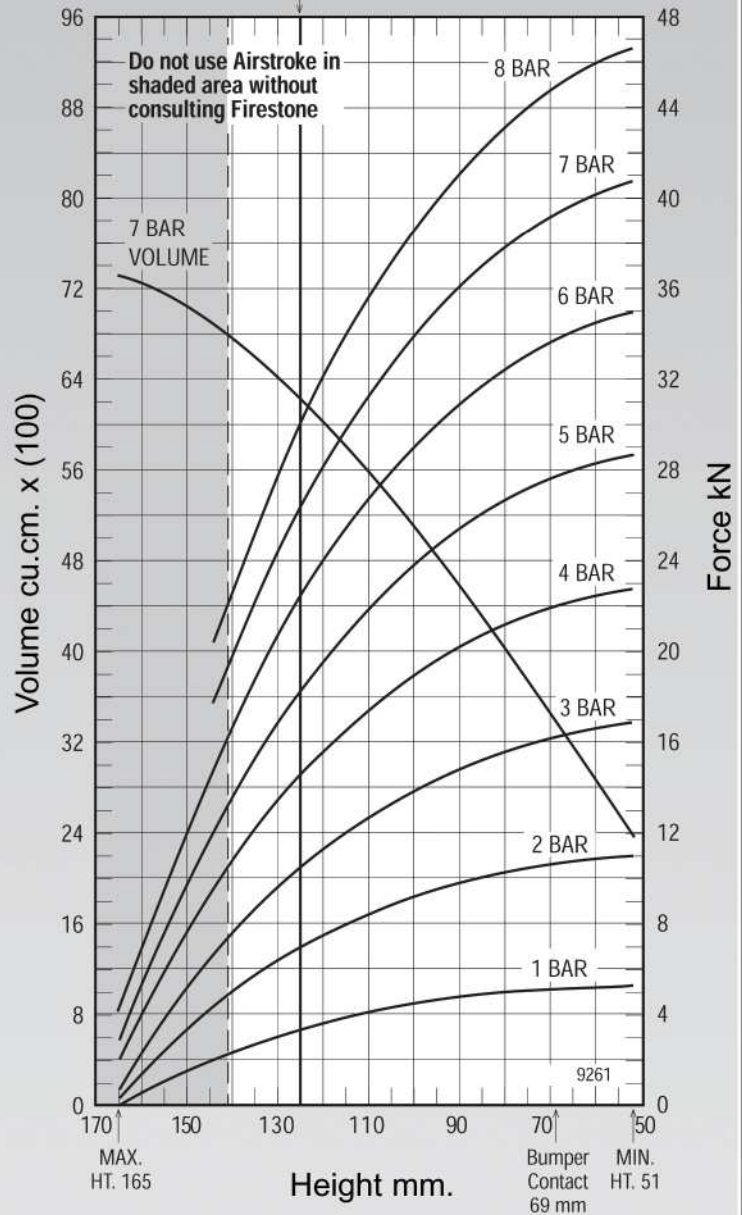

See page 12 for instructions on how to use chart.

Dynamic Characteristics at 125 mm Design Height (Required for Airmount isolator design only)			
Gauge Pressure (BAR)	Load (kN)	Spring Rate (kN/m)	Natural Frequency Hz
3	10.49	290	2.62
4	14.46	383	2.57
5	18.21	471	2.54
6	22.34	559	2.49
7	26.15	641	2.47

Force Table (Use for Airstroke™ actuator design)							
Assembly Height (mm)	Volume @ 7 BAR (cu cm)	EFF Area @ 7 BAR (cm sq)	kN Force				
			@ 3 BAR	@ 4 BAR	@ 5 BAR	@ 6 BAR	@ 7 BAR
130	6379	345	9.61	13.28	16.74	20.60	24.15
120	6004	398	11.24	15.49	19.48	23.85	27.87
110	5555	444	12.67	17.39	21.84	26.65	31.10
100	5093	482	13.85	18.90	23.74	28.92	33.71
90	4566	513	14.87	20.18	25.35	30.86	35.94
80	4048	539	15.67	21.16	26.59	32.38	37.69
70	3474	559	16.27	21.93	27.58	33.60	39.13
60	2923	574	16.68	22.48	28.26	34.45	40.15

**NOTE: All Assembly Order Numbers are for bead plate parts unless noted otherwise.**

	Description	Assembly Order No.
Style 19-.75	Blind nuts, 1/4 BSP	W01-M58-6040
Two Ply Bellows		
Assembly weight (bead plate version, no bumper)		4.53 kg.
Force to collapse to minimum height (@ 0 BAR)		67 N.

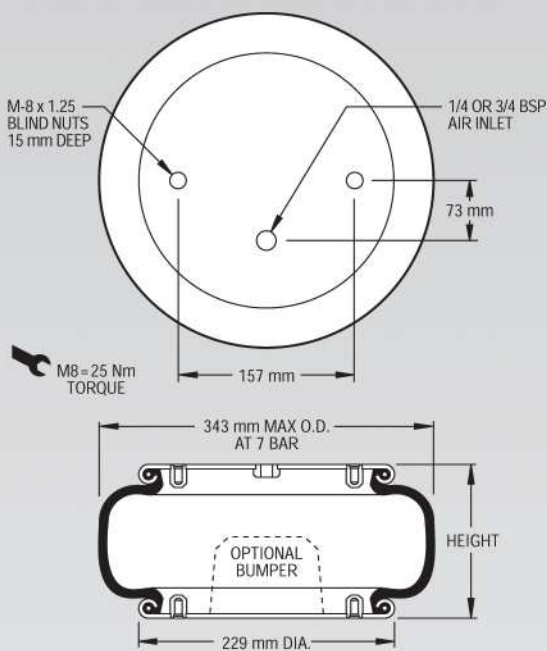

**NOTE: A bead plate part is shown. This part is also available with bead rings. See pages 8-10 for explanation.**

Gauge Pressure (BAR)	Load (kN)	Spring Rate (kN/m)	Natural Frequency Hz
3	9.30	272	2.70
4	12.89	356	2.62
5	16.44	435	2.57
6	20.49	514	2.50
7	24.11	589	2.46

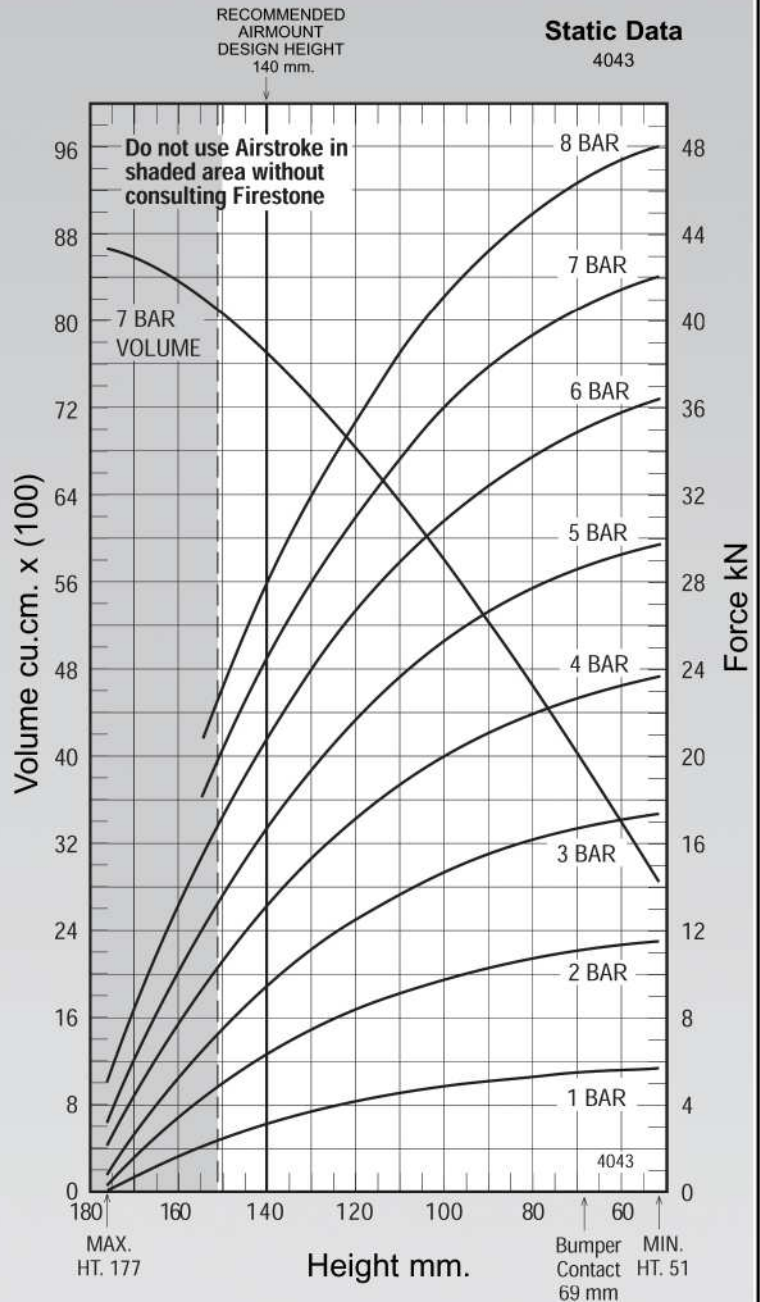

See page 12 for instructions on how to use chart.

Assembly Height (mm)	Volume @ 7 BAR (cu cm)	EFF Area @ 7 BAR (cm sq)	kN Force				
			@ 3 BAR	@ 4 BAR	@ 5 BAR	@ 6 BAR	@ 7 BAR
140	7705	345	9.30	12.89	16.44	20.49	24.11
130	7286	397	11.01	15.15	19.21	23.73	27.81
120	6846	441	12.41	17.00	21.52	26.44	30.89
110	6335	480	13.64	18.63	23.55	28.84	33.62
100	5822	512	14.65	19.94	25.19	30.79	35.86
90	5243	540	15.50	21.06	26.57	32.45	37.80
80	4681	562	16.18	21.93	27.65	33.77	39.34
70	4063	580	16.73	22.65	28.54	34.84	40.60

**NOTE: All Assembly Order Numbers are for bead plate parts unless noted otherwise.**

	Description	Assembly Order No.
Style 113	Blind nuts, 1/4 BSP	W01-M58-6101
	Blind nuts, 1/4 BSP, bumper	W01-M58-6103
Two Ply Bellows	Blind nuts, 3/4 BSP	W01-M58-6100
	Blind nuts, 3/4 BSP, bumper	W01-M58-6102
	Countersunk steel bead rings 40 mm bolts, nuts washers	W01-M58-7538
	Rubber bellows only	W01-358-0135

Assembly weight.....6.58 kg.  
Force to collapse to minimum height (@ 0 BAR) 76 N.

Style 128	Blind nuts, 1/4 BSP	W01-M58-6071
	Blind nuts, 1/4 BSP, rubber bumper	W01-M58-6068
High Strength Construction	Blind nuts, 3/4 BSP	W01-M58-6070
	Blind nuts, 3/4 BSP, rubber bumper	W01-M58-6069
	Rubber bellows only	W01-358-0231

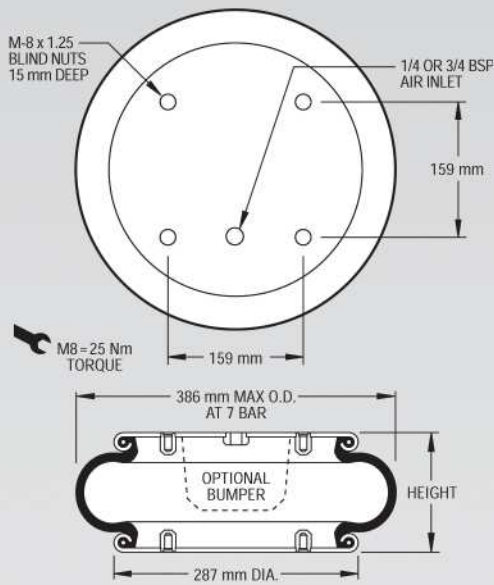

**NOTE: A bead plate part is shown. This part is also available with bead rings. See pages 8-10 for explanation.**

Dynamic Characteristics at 125 mm Design Height (Required for Airmount isolator design only)			
Gauge Pressure (BAR)	Load (kN)	Spring Rate (kN/m)	Natural Frequency Hz
3	16.72	416	2.49
4	22.90	534	2.41
5	28.97	651	2.36
6	35.62	774	2.32
7	41.65	890	2.31

RECOMMENDED  
AIRMOUNT  
DESIGN HEIGHT  
125 mm.

**Static Data**  
4002

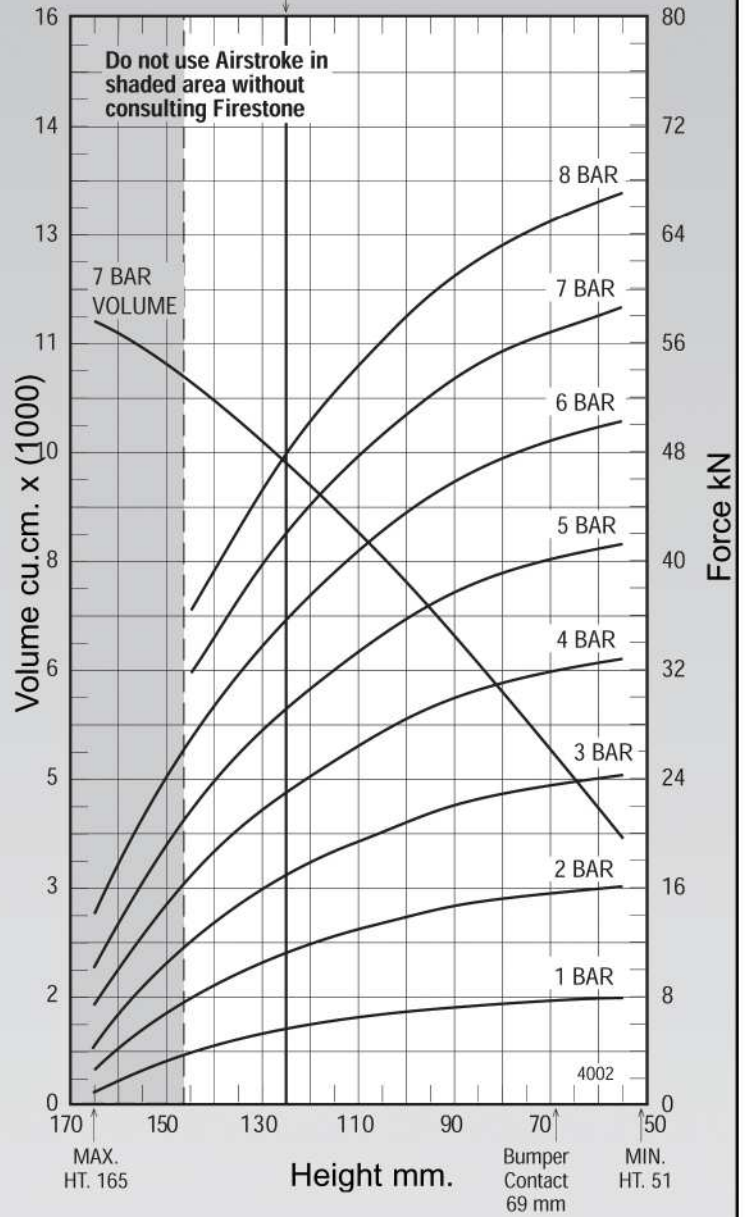

See page 12 for instructions on how to use chart.

Force Table (Use for Airstroke™ actuator design)							
Assembly Height (mm)	Volume @ 7 BAR (cu cm)	EFF Area @ 7 BAR (cm sq.)	kN Force				
			@ 3 BAR	@ 4 BAR	@ 5 BAR	@ 6 BAR	@ 7 BAR
140	10316	486	13.02	18.16	23.20	28.93	34.00
130	9720	562	15.62	21.49	27.24	33.59	39.30
120	9110	624	17.66	24.10	30.44	37.37	43.68
110	8411	679	19.40	26.36	33.22	40.69	47.53
100	7714	724	20.81	28.23	35.53	43.42	50.66
90	6929	762	22.00	29.85	37.54	45.76	53.31
80	6159	790	22.89	31.08	39.05	47.53	55.33
70	5306	813	23.54	31.96	40.13	48.87	56.93

**NOTE: All Assembly Order Numbers are for bead plate parts unless noted otherwise.**

	Description	Assembly Order No.
Style 113-1	Blind nuts, 1/4 BSP	W01-M58-6371
	Blind nuts, 3/4 BSP	W01-M58-6369
Two Ply Bellows	Countersunk steel bead rings, 40 mm bolts, nuts, washers	W01-M58-7539
	Rubber bellows only	W01-358-0150
Assembly weight.....		6.89 kg.
Force to collapse to minimum height (@ 0 BAR)		111 N.

Style 128-1	Blind nuts, 3/4 BSP	W01-M58-6066
	Blind nuts, 1/4 BSP	W01-M58-6067
High Strength Construction		

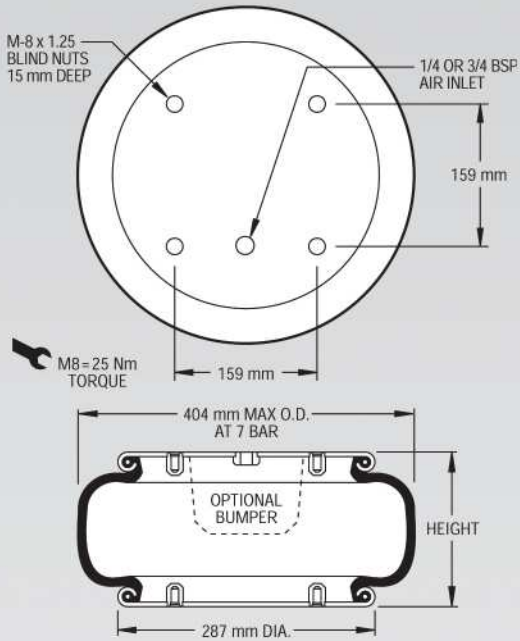

**NOTE: A bead plate part is shown. This part is also available with bead rings. See pages 8-10 for explanation.**

**Static Data**  
A8915

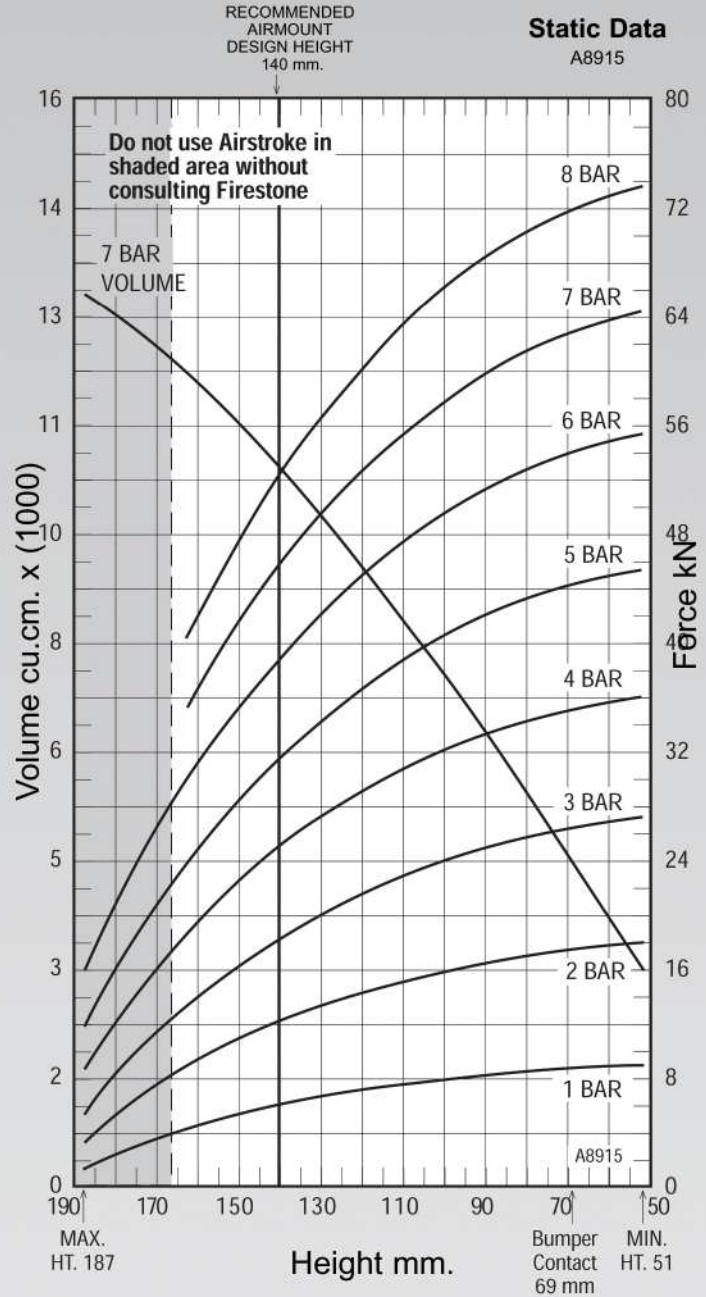

See page 12 for instructions on how to use chart.

Dynamic Characteristics at 140mm Design Height (Required for Airmount isolator design only)			
Gauge Pressure (BAR)	Load (kN)	Spring Rate (kN/m)	Natural Frequency Hz
3	18.07	416	2.39
4	24.76	529	2.31
5	31.33	646	2.27
6	38.72	771	2.23
7	45.44	887	2.20

Force Table (Use for Airstroke™ actuator design)							
Assembly Height (mm)	Volume @ 7 BAR (cu cm)	EFF Area @ 7 BAR (cm sq.)	kN Force				
			@ 3 BAR	@ 4 BAR	@ 5 BAR	@ 6 BAR	@ 7 BAR
160	11771	516	13.58	19.08	24.39	30.59	36.10
140	10492	649	18.07	24.76	31.33	38.72	45.44
120	9061	750	21.39	28.92	36.48	44.84	52.49
100	7479	825	23.91	32.03	40.34	49.41	57.72
80	5781	878	25.75	34.28	43.15	52.69	61.43
60	4002	911	26.85	35.69	44.94	54.78	63.79

**NOTE: All Assembly Order Numbers are for bead plate parts unless noted otherwise.**

	Description	Assembly Order No.
Style 153-2	Blind nuts, 1/4 NPT	WO1-358-8158
Two Ply Bellows		
Assembly weight.....		7.86 kg

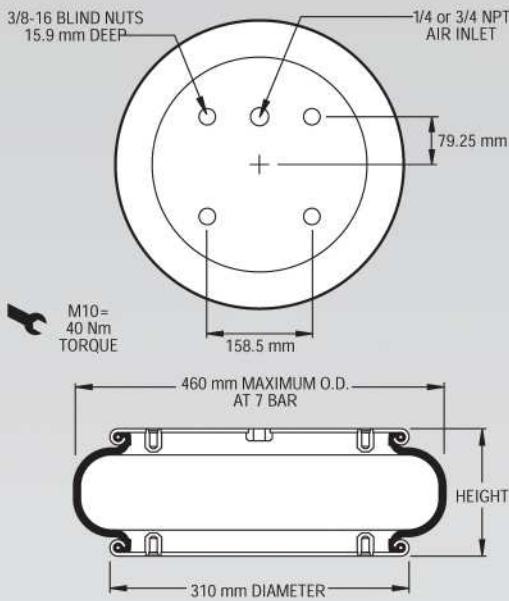

**NOTE: A bead plate part is shown. This part is also available with bead rings. See pages 8-10 for explanation.**

Dynamic Characteristics at 150 mm Design Height (Required for Airmount isolator design only)			
Gauge Pressure (BAR)	Load (kN)	Spring Rate (kN/m)	Natural Frequency Hz
3	22.39	428.74	2.18
4	30.72	555.60	2.12
5	39.04	673.69	2.07
6	48.29	794.88	2.02
7	56.58	911.22	2.00

RECOMMENDED AIRMOUNT DESIGN HEIGHT 150 mm.

**Static Data**  
B4561

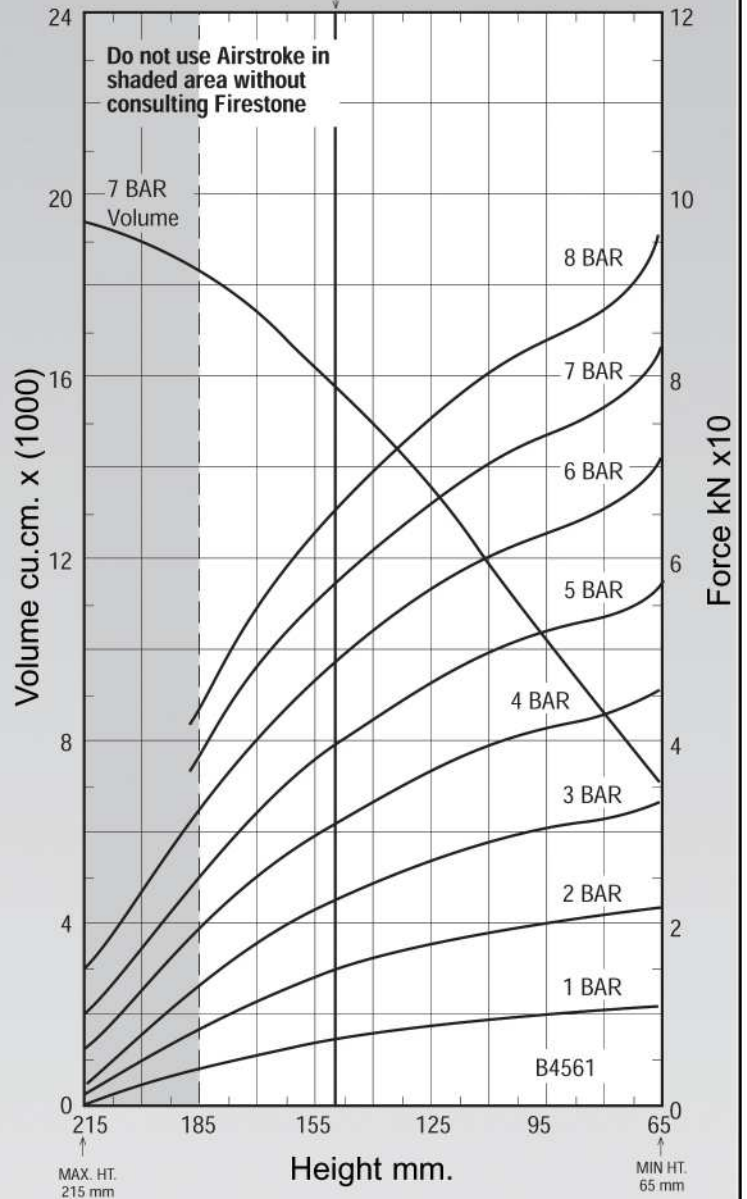

See page 12 for instructions on how to use chart.

Force Table (Use for Airstroke™ actuator design)							
Assembly Height (mm)	Volume @ 7 BAR (cu cm)	EFF Area @ 7 BAR (cm sq)	kN Force				
			@ 3 BAR	@ 4 BAR	@ 5 BAR	@ 6 BAR	@ 7 BAR
180	18085	586	14.48	21.09	27.34	34.71	41.03
165	17075	710	19.02	26.49	33.92	42.34	49.74
150	15865	808	22.39	30.72	39.04	48.29	56.58
135	14493	890	25.09	34.38	43.44	53.33	62.31
120	13057	960	27.37	37.61	47.34	57.70	67.20
105	11469	1016	29.32	40.21	50.50	61.28	71.18
90	9891	1054	30.76	41.86	52.56	63.81	74.18
75	8291	1112	32.00	43.34	54.47	66.62	77.85

**NOTE: All Assembly Order Numbers are for bead ring parts unless noted otherwise.**

	Description	Assembly Order No.
Style 119	Ribbed neck aluminum bead rings (equal spacing), 45 mm bolts, nuts, washers	W01-M58-6974
Two Ply Bellows	Rubber bellows only	W01-358-0119
	Rolled plate assembly, 1/2 blind nuts, 3/4 BSP	SEE NOTE BELOW
Assembly weight.....		5.98 kg.
Force to collapse to minimum height (@ 0 BAR)		76 N.

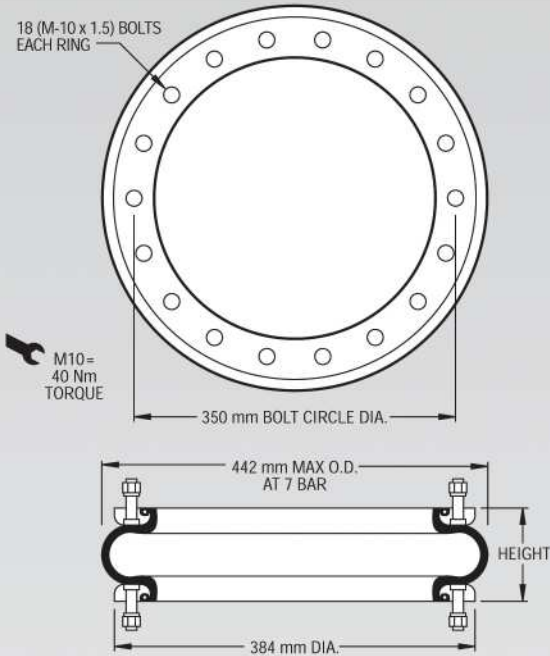

**NOTE: A bead plate part is shown. This part is also available with rolled plates. See page 11 for explanation.**

Gauge Pressure (BAR)	Load (kN)	Spring Rate (kN/m)	Natural Frequency Hz
3	26.86	599	2.35
4	36.82	766	2.27
5	46.53	934	2.23
6	57.15	1109	2.20
7	66.80	1269	2.17

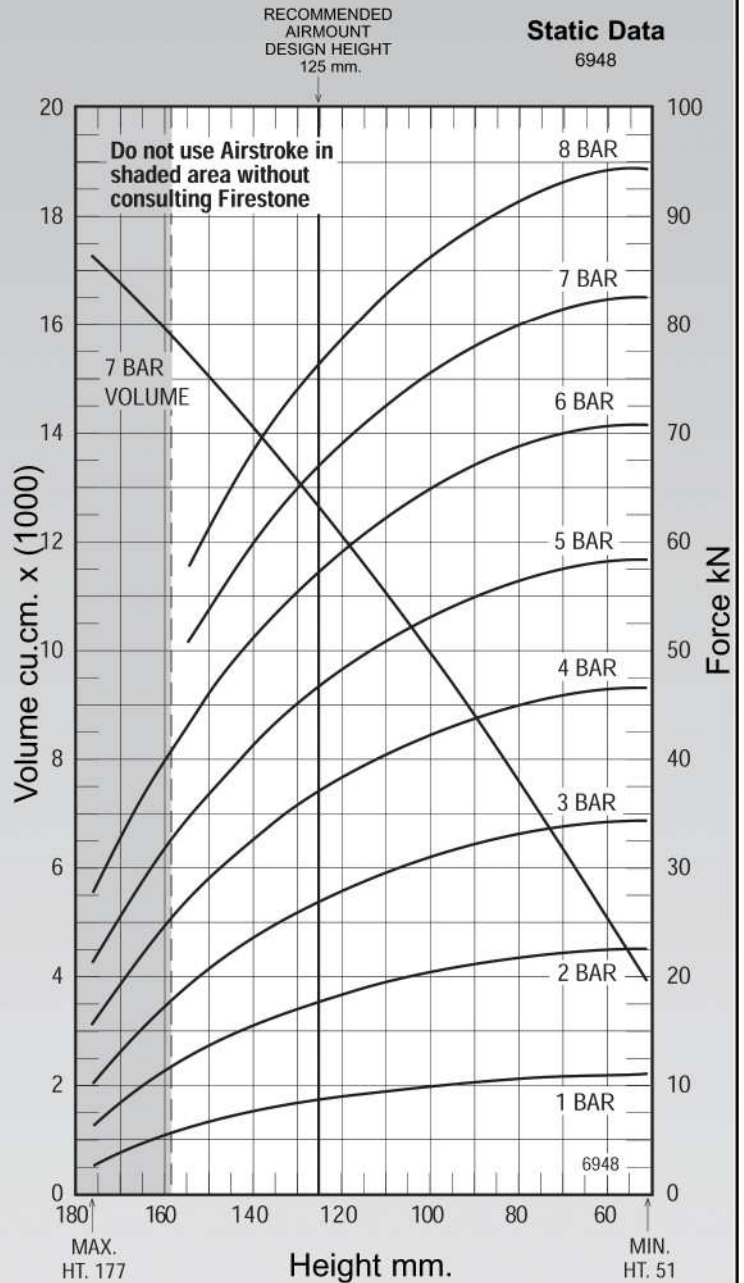

See page 12 for instructions on how to use chart.

Assembly Height (mm)	Volume @ 7 BAR (cu cm)	EFF Area @ 7 BAR (cm sq)	kN Force				
			@ 3 BAR	@ 4 BAR	@ 5 BAR	@ 6 BAR	@ 7 BAR
140	14081	847	23.26	32.31	40.96	50.59	59.29
130	13097	922	25.78	35.46	44.84	55.17	64.52
120	12133	982	27.78	37.99	47.98	58.85	68.74
110	11058	1033	29.48	40.18	50.67	62.00	72.34
100	10008	1075	30.83	41.97	52.85	64.53	75.23
90	8840	1110	31.99	43.53	54.73	66.70	77.72
80	7704	1139	32.96	44.81	56.25	68.45	79.72
70	6445	1162	33.79	45.85	57.48	69.86	81.34

**NOTE: All Assembly Order Numbers are for bead ring parts unless noted otherwise.**

	Description	Assembly Order No.
Style 121	Ribbed neck aluminum bead rings, 45 mm bolts, nuts, washers	W01-M58-6966
Two Ply Bellows	Rolled plate assembly, 1/2 blind nuts, 3/4 BSP	SEE NOTE BELOW
	Rubber bellows only	W01-358-5135
Assembly weight.....		7.26 kg.
Force to collapse to minimum height (@ 0 BAR)		89 N.

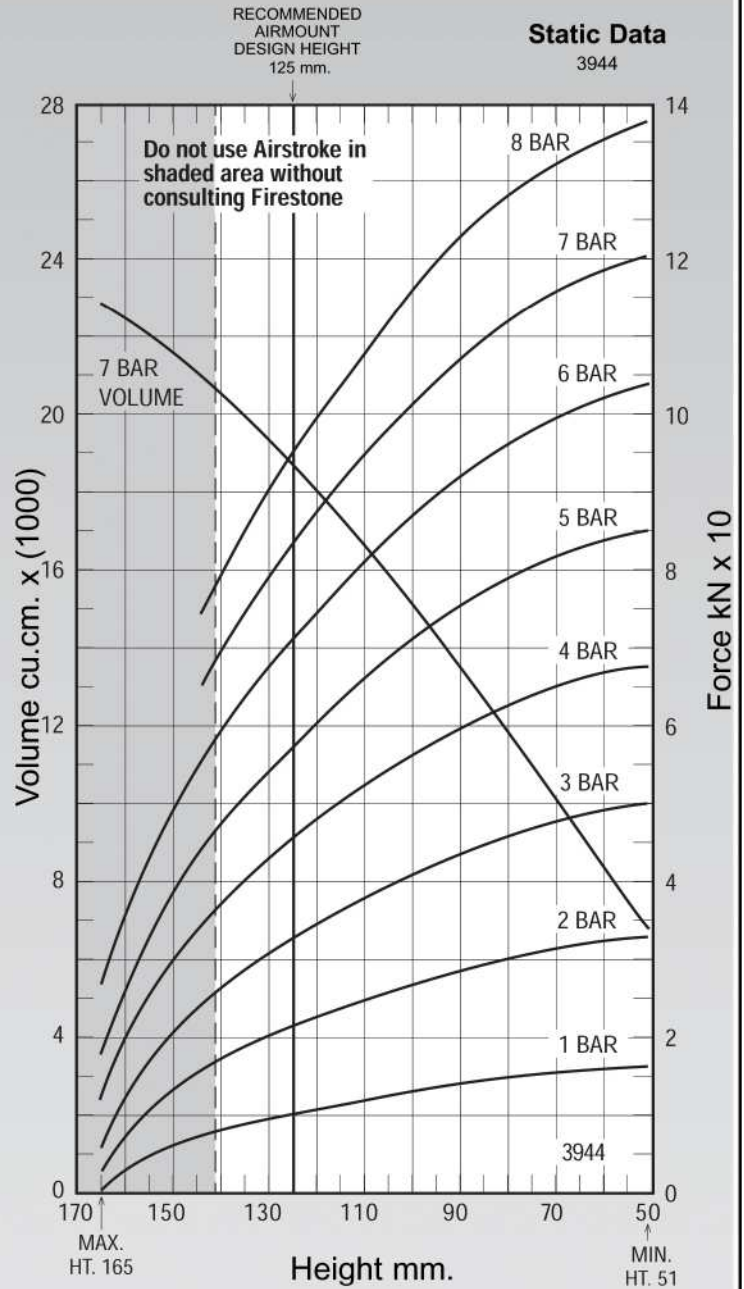
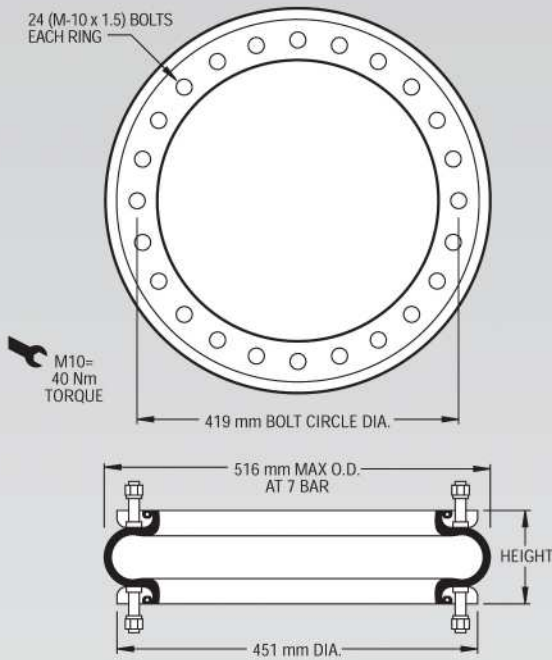

**NOTE: A bead ring part is shown. This part is also available with rolled plates. See page 11 for explanation.**

**See page 12 for instructions on how to use chart.**

Dynamic Characteristics at 125 mm Design Height (Required for Airmount isolator design only)			
Gauge Pressure (BAR)	Load (kN)	Spring Rate (kN/m)	Natural Frequency Hz
3	32.46	812	2.49
4	45.13	1058	2.41
5	57.13	1298	2.38
6	70.61	1535	2.33
7	82.85	1750	2.29

Force Table (Use for Airstroke™ actuator design)							
Assembly Height (mm)	Volume @ 7 BAR (cu cm)	EFF Area @ 7 BAR (cm sq)	kN Force				
			@ 3 BAR	@ 4 BAR	@ 5 BAR	@ 6 BAR	@ 7 BAR
130	19228	1122	30.41	42.47	53.82	66.78	78.52
120	17985	1239	34.26	47.49	60.07	74.04	86.72
110	16552	1350	37.72	52.13	65.82	80.82	94.46
100	15121	1446	40.64	56.07	70.70	86.63	101.20
90	13511	1531	43.26	59.58	74.98	91.75	107.17
80	11939	1599	45.55	62.46	78.47	95.84	111.88
70	10205	1653	47.72	64.98	81.51	99.23	115.66

**NOTE: All Assembly Order Numbers are for bead ring parts unless noted otherwise.**

	Description	Assembly Order No.
Style 126	Ribbed neck aluminum bead rings (equal spacing), 45 mm bolts, nuts, washers	W01-M58-6973
Two Ply Bellows	Rolled plate assembly, 1/2 blind nuts, 3/4 BSP	SEE NOTE BELOW
	Rubber bellows only	W01-358-1026
Assembly weight.....		9.66 kg.
Force to collapse to minimum height (@ 0 BAR)		111 N.

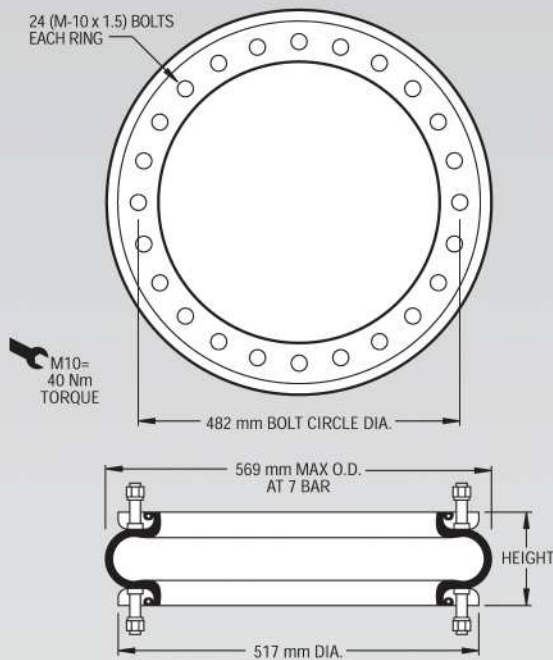

**NOTE: A bead ring part is shown. This part is also available with rolled plates. See page 11 for explanation.**

RECOMMENDED  
AIRMOUNT  
DESIGN HEIGHT  
125 mm.

**Static Data**  
8701

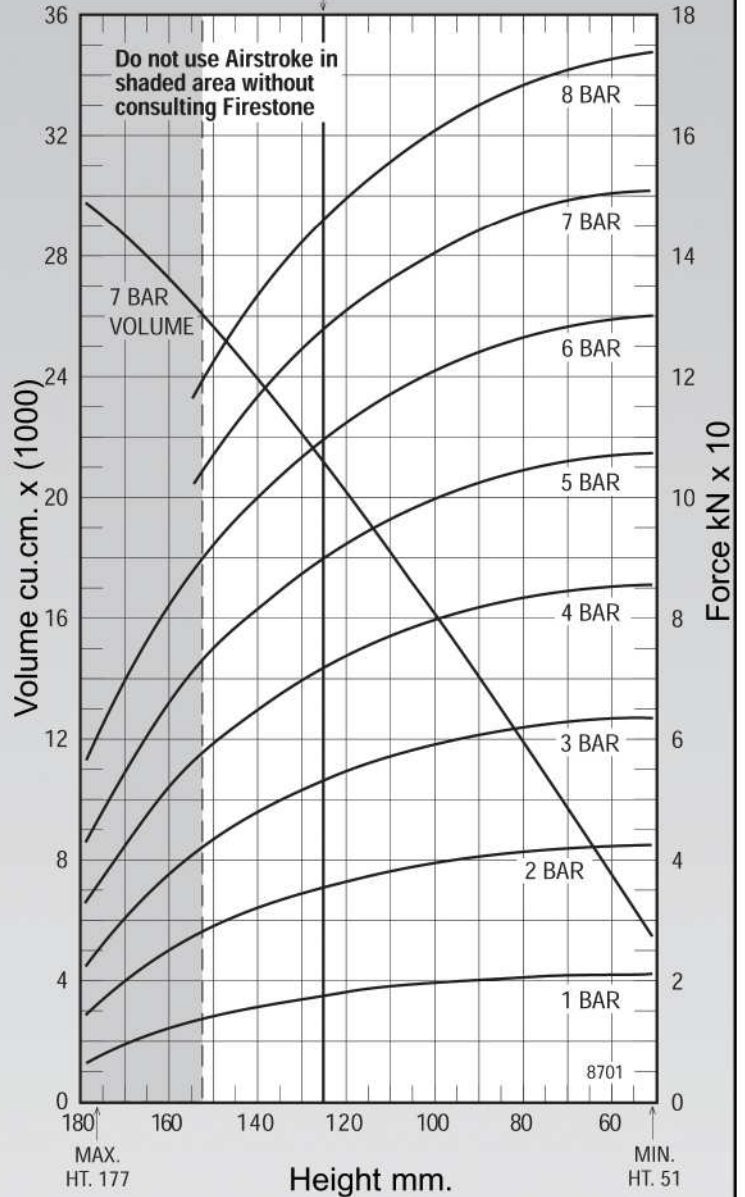

See page 12 for instructions on how to use chart.

**Dynamic Characteristics at 125 mm Design Height**  
(Required for Airmount isolator design only)

Gauge Pressure (BAR)	Load (kN)	Spring Rate (kN/m)	Natural Frequency Hz
3	53.10	1184	2.35
4	71.42	1512	2.29
5	89.75	1828	2.25
6	109.40	2154	2.21
7	127.49	2458	2.19

**Force Table (Use for Airstroke™ actuator design)**

Assembly Height (mm)	Volume @ 7 BAR (cu cm)	EFF Area @ 7 BAR (cm sq)	kN Force				
			@ 3 BAR	@ 4 BAR	@ 5 BAR	@ 6 BAR	@ 7 BAR
160	27186	1355	37.05	51.09	64.81	80.58	94.86
140	23871	1660	47.71	64.48	81.24	99.48	116.20
120	20206	1863	54.46	73.23	91.96	111.95	130.41
100	16216	2006	58.95	79.48	99.52	120.68	140.38
80	12022	2101	62.03	83.35	104.45	126.58	147.09
60	7743	2153	63.76	85.23	106.86	129.60	150.66



**NOTE: All Assembly Order Numbers are for bead ring parts unless noted otherwise.**

	Description	Assembly Order No.
Style 138-1.5	Ribbed neck aluminum bead rings (equal spacing), 45 mm bolts, nuts, washers	W01-M58-6972
High Strength Construction	Rubber bellows only	W01-358-0147
Assembly weight.....		11.11 kg.
Force to collapse to minimum height (@ 0 BAR)		667 N.

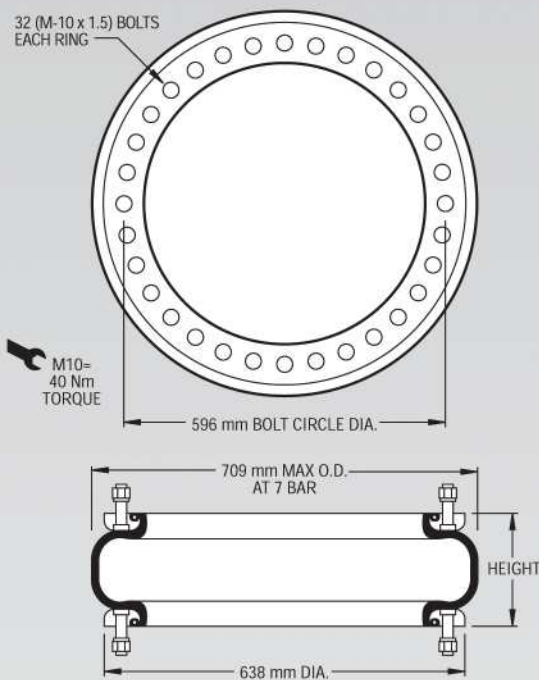

**NOTE: A bead ring part is shown. This part is also available with rolled plates. See page 11 for explanation.**

Gauge Pressure (BAR)	Load (kN)	Spring Rate (kN/m)	Natural Frequency Hz
3	78.40	1361	2.08
4	106.51	1742	2.02
5	134.29	2111	1.98
6	164.07	2488	1.94
7	191.19	2844	1.92

RECOMMENDED AIRMOUNT DESIGN HEIGHT 150 mm.

**Static Data**  
3575

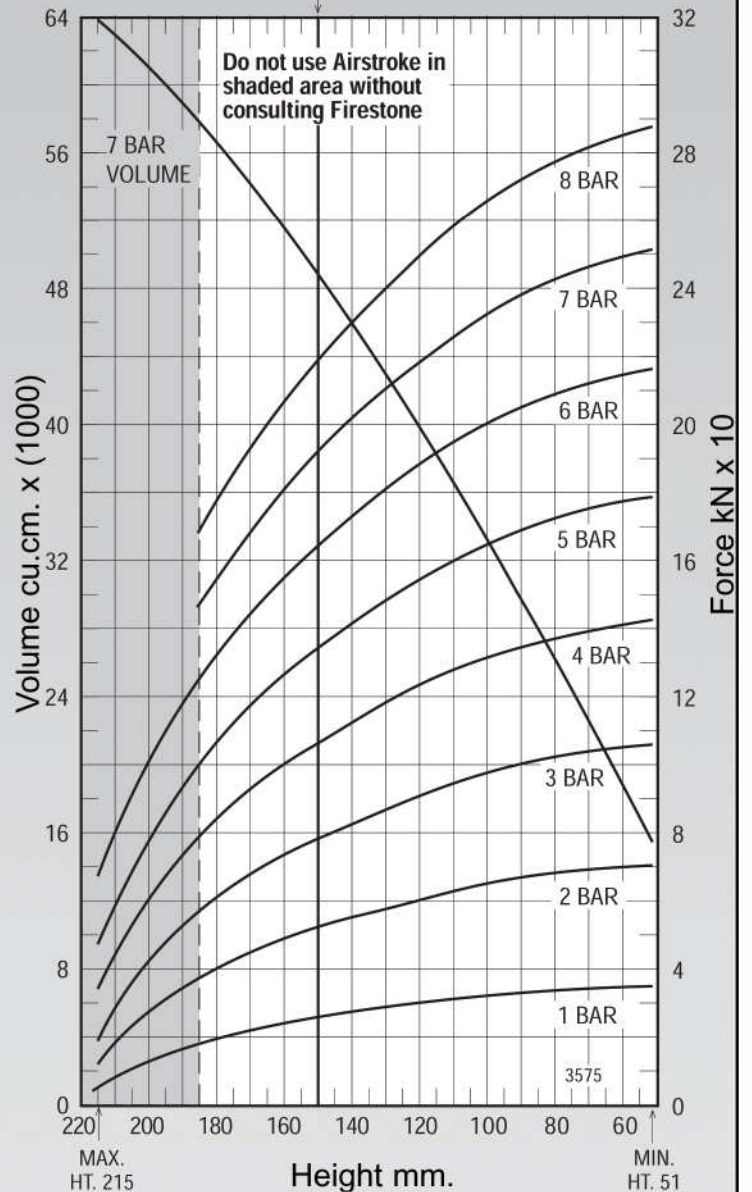

See page 12 for instructions on how to use chart.

Assembly Height (mm)	Volume @ 7 BAR (cu cm)	EFF Area @ 7 BAR (cm sq)	kN Force				
			@ 3 BAR	@ 4 BAR	@ 5 BAR	@ 6 BAR	@ 7 BAR
180	56558	2200	60.35	83.40	106.09	131.40	153.99
160	51417	2573	73.03	99.66	125.96	154.37	180.09
140	45680	2871	83.06	112.54	141.62	172.60	200.97
120	39615	3120	91.25	123.17	154.62	187.80	218.40
100	33114	3322	97.72	131.55	165.06	200.15	232.53
80	26237	3471	102.53	137.62	172.72	209.27	242.92
60	19043	3567	105.89	141.79	177.80	215.18	249.69

**NOTE: All Assembly Order Numbers are for bead ring parts unless noted otherwise.**

	Description	Assembly Order No.
Style 148-1	Ribbed neck aluminum bead rings (equal spacing), 45 mm bolts, nuts, washers	W01-M58-6969
High Strength Construction	Rubber bellows only	W01-358-1021
Assembly weight.....		21.00 kg.
Force to collapse to minimum height (@ 0 BAR)		1378 N.

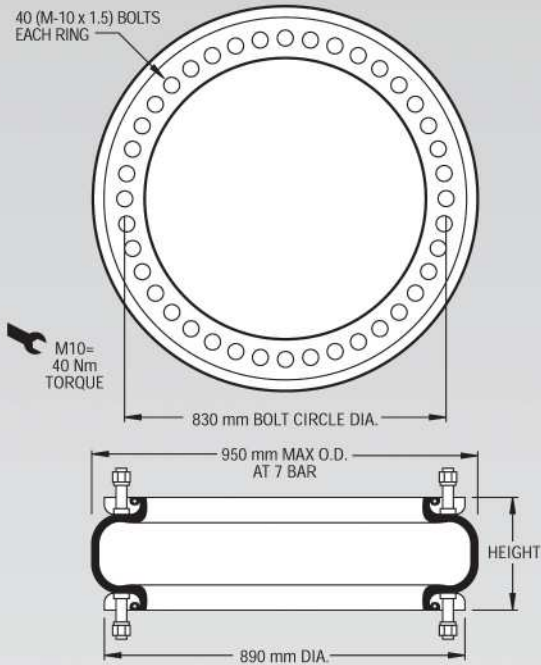

RECOMMENDED  
AIRMOUNT  
DESIGN HEIGHT  
140 mm.

**Static Data**  
8411

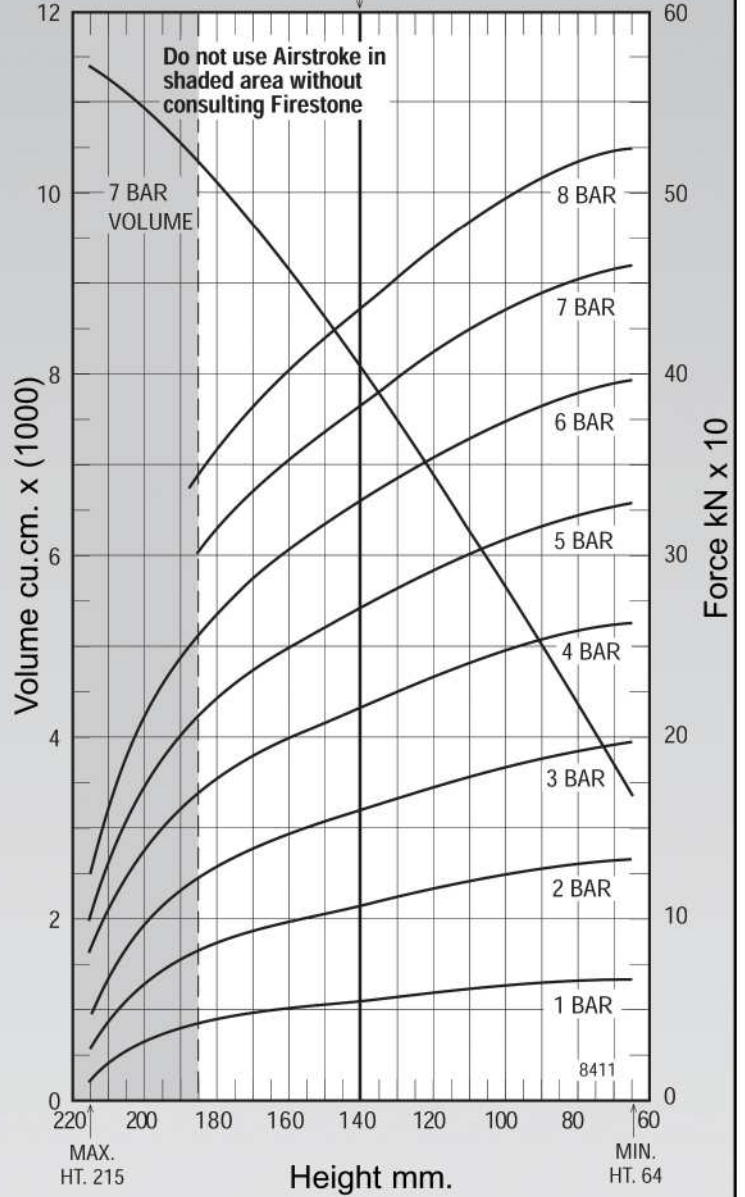

**NOTE: The effective length of the 45 mm bolt is 23 mm in this bead ring.**

See page 12 for instructions on how to use chart.

Dynamic Characteristics at 140 mm Design Height (Required for Airmount isolator design only)			
Gauge Pressure (BAR)	Load (kN)	Spring Rate (kN/m)	Natural Frequency Hz
3	159.12	2747	2.07
4	214.60	3485	2.01
5	268.86	4248	1.98
6	327.14	5077	1.96
7	381.44	5830	1.95

Force Table (Use for Airstroke™ actuator design)							
Assembly Height (mm)	Volume @ 7 BAR (cu cm)	EFF Area @ 7 BAR (cm sq)	kN Force				
			@ 3 BAR	@ 4 BAR	@ 5 BAR	@ 6 BAR	@ 7 BAR
180	100532	4456	126.24	174.51	218.75	266.95	311.89
160	90826	4998	144.99	197.24	247.10	300.31	349.83
140	79989	5450	159.12	214.60	268.86	327.14	381.44
120	68618	5857	170.91	230.51	289.23	351.92	409.95
100	56587	6199	181.41	245.45	307.57	373.08	433.88
80	44091	6455	191.45	257.88	321.60	388.59	451.81

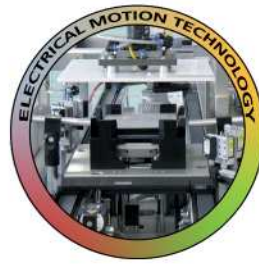

*We look forward to your application.*

**LDA Belgium**

Hoge Buizen 53  
1980 Eppegem  
Belgium

Tel. +32 (0)2-266 13 13  
Mail: [LDA@LDA.be](mailto:LDA@LDA.be)

[www.LDA.be](http://www.LDA.be)