

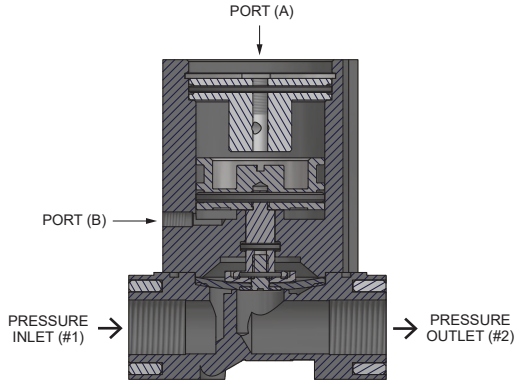

Series APVS06

Application and Installation Guide

Two-Way, Two Position, Double Acting



Requires a 4/2 way pilot valve to operate.

The Double Acting option can be set up either normally open or normally closed. For a double acting APVS06 set up to be normally closed, the normally open pilot port on the 4-way valve will be attached to the top port (A) on the APVS06. For the APVS06 to be normally open, switch the normally open 4-way port to port (B)

Closed position - Pilot supply is connected to port (A). Piston/diaphragm assembly is held firm against the valve orifice by the force of the pilot supply. Media flow passage port #1 to port #2 is blocked.

Open position - Pilot supply is shifted to port (B) allowing pressure to enter the cylinder creating a force to raise the piston/diaphragm assembly. Media flows from port #1 to port #2.



Series APVS06

Application and Installation Guide

Two-Way, Two Position, Double Acting

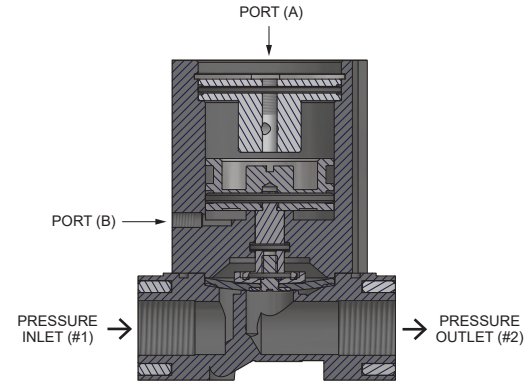

Requires a 4/2 way pilot valve to operate.

The Double Acting option can be set up either normally open or normally closed. For a double acting APVS06 set up to be normally closed, the normally open pilot port on the 4-way valve will be attached to the top port (A) on the APVS06. For the APVS06 to be normally open, switch the normally open 4-way port to port (B)

Closed position - Pilot supply is connected to port (A). Piston/diaphragm assembly is held firm against the valve orifice by the force of the pilot supply. Media flow passage port #1 to port #2 is blocked.

Open position - Pilot supply is shifted to port (B) allowing pressure to enter the cylinder creating a force to raise the piston/diaphragm assembly. Media flows from port #1 to port #2.

Two-Way, Two Position, Normally Closed

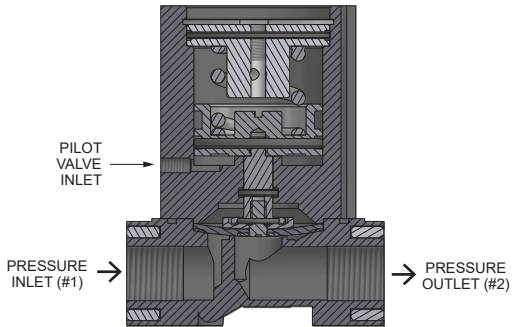

Requires a 3/2 way normally closed pilot valve to operate.

Closed (normal) position - Pilot supply is connected to pilot valve inlet and is blocked. Controlled media is connected to port #1. Piston/diaphragm assembly is held firm against the valve orifice by means of main spring. Media flow passage from port #1 to port #2 is blocked.

Open position - Solenoid is energized opening the pilot inlet. Pilot supply is opened allowing pressure to enter the cylinder creating the force to raise the piston/diaphragm assembly. Media flows from port #1 to port #2.

Two-Way, Two Position, Normally Closed

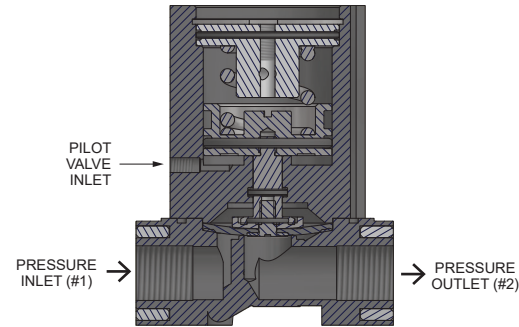

Requires a 3/2 way normally closed pilot valve to operate.

Closed (normal) position - Pilot supply is connected to pilot valve inlet and is blocked. Controlled media is connected to port #1. Piston/diaphragm assembly is held firm against the valve orifice by means of main spring. Media flow passage from port #1 to port #2 is blocked.

Open position - Solenoid is energized opening the pilot inlet. Pilot supply is opened allowing pressure to enter the cylinder creating the force to raise the piston/diaphragm assembly. Media flows from port #1 to port #2.



Series APVS06

Application and Installation Guide

Mounting

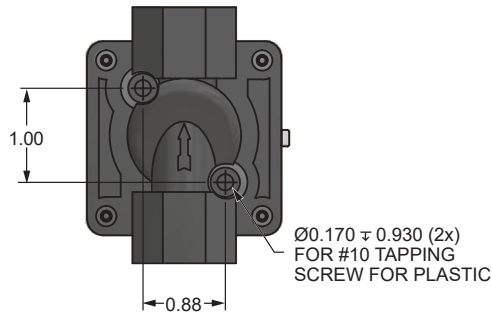

Caution

Excessive use of pipe sealant can cause clogging and leakage. Please follow ASME standards for applying pipe sealant and tape. Do not use media, voltage or pressures other than that recommended by Spartan Scientific Inc. as valve malfunction could result. Misuse or misapplication of Spartan solenoid valves could cause serious bodily injury or property damage.

Warning - Contents are under pressure.

Warranty Information

Solenoid valves and all other products manufactured by Spartan are warranted by Spartan to be free from defects in material and workmanship for a period of 1 year from the date of purchase. Spartan's obligation under this warranty is limited to repair or replacement of the defective product or refund of the purchase price paid solely at the discretion of Spartan and provided such defective product is returned to Spartan freight prepaid and upon examination by Spartan such product is found defective. This warranty shall be void in the event that the product has been subject to misuse, misapplication, improper maintenance, modification or tampering. This warranty is expressed in lieu of all other warranties, expressed or implied from Spartan Scientific, Inc., representatives or employees.



Hoge Buizen 53 -1980 EPEGEM (BE)
www.LDA.be - LDA@LDA.be
 +32(0) 2 266 13 13



Series APVS06

Application and Installation Guide

Mounting

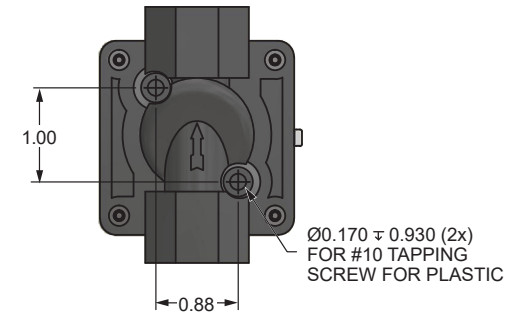

Caution

Excessive use of pipe sealant can cause clogging and leakage. Please follow ASME standards for applying pipe sealant and tape. Do not use media, voltage or pressures other than that recommended by Spartan Scientific Inc. as valve malfunction could result. Misuse or misapplication of Spartan solenoid valves could cause serious bodily injury or property damage.

Warning - Contents are under pressure.

Warranty Information

Solenoid valves and all other products manufactured by Spartan are warranted by Spartan to be free from defects in material and workmanship for a period of 1 year from the date of purchase. Spartan's obligation under this warranty is limited to repair or replacement of the defective product or refund of the purchase price paid solely at the discretion of Spartan and provided such defective product is returned to Spartan freight prepaid and upon examination by Spartan such product is found defective. This warranty shall be void in the event that the product has been subject to misuse, misapplication, improper maintenance, modification or tampering. This warranty is expressed in lieu of all other warranties, expressed or implied from Spartan Scientific, Inc., representatives or employees.



8510 Foxwood Ct. • Youngstown, Ohio 44514
 PH: (855)629-4648 • Fax: (330)758-3314
www.spartanscientific.com