

EH70 SERIES 1/2" TO 2" PIPE SIZE



Features:

The powerful, full port EH70 is a 2-way, unidirectional solenoid valve that is great for a wide range of temperatures, fluids and gases. It is a popular choice for natural gas applications in hazardous locations, as well as cryogenic conditions. This pilot assisted, direct operated valve can be configured with an Explosion Proof certified coil for all hazardous locations. Orifice sizes range from 1/2" to 2", and allow maximum inlet pressures of up to 1,500 PSIG. The versatile EH70 requires no minimum pressure for opening, and for sizes 1/2" & 3/4" sizes, can be mounted in any orientation. Normally Closed and Normally Open configurations are available for all sizes. This valve is CRN certified with all Canadian provinces. The stainless steel and PTFE internal components allow such media as deionized water, condensate, ammonias, vegetable oils, fuel oils, natural gas, hydrogen, cryogenics, flammable liquids and gases and other gases or liquids compatible with materials of construction. **Filters recommended for all applications.**

How To Order

Base Model Number		Connection size in NPT		Connection type		AC/DC Voltage and Hertz		Fluid		Suffix Option Field (s)	
EH70		[]		[]		[]		[]		[]	
08	1/2"	A	NPT	A024	24 / 60	G	Gas	NO	Normally Open		
12	3/4"	B	Socket Weld	A120	120 / 60	L	Liquid	OX	Oxygen Clean		
16	1"	G	150# Flange	A240	240 / 60	D	Liquid + Gas	HY	Class 5 Leakage Test with Helium		
24	1 1/2"	H	300# Flange	D024	24 DC			CY	Cryogenic Service		
32	2"	J	600# Flange	D120	120 DC			DN	Din Connector (Not Explosion Proof)		
				D240	240 DC			S1	Single Switch (General Service)		
								X1	Single Switch (Explosion Proof)		
								SS	Stainless Steel Tags		
								ETL	ETL Certified / Explosion Proof		
								T5	Class 5 Leakage Test with Air		
								MN	Manual Override (1/2" to 1")		

Note for Dual Service "D" Option:

Code 'D' is to be used with Mixed Gas and Liquid, including Cryogenic Fluid.

It is not available in the 2" Size.

Possible Media

General Gases and Liquids	Fuels & Light Oils	Flammable Gases	Hydrogen	Oxygen	Corrosives	Sea & Salt Water	Viscous Liquids	Steam	Cryogenics

EH70 SERIES 1/2" TO 2" PIPE SIZE

Dimensions

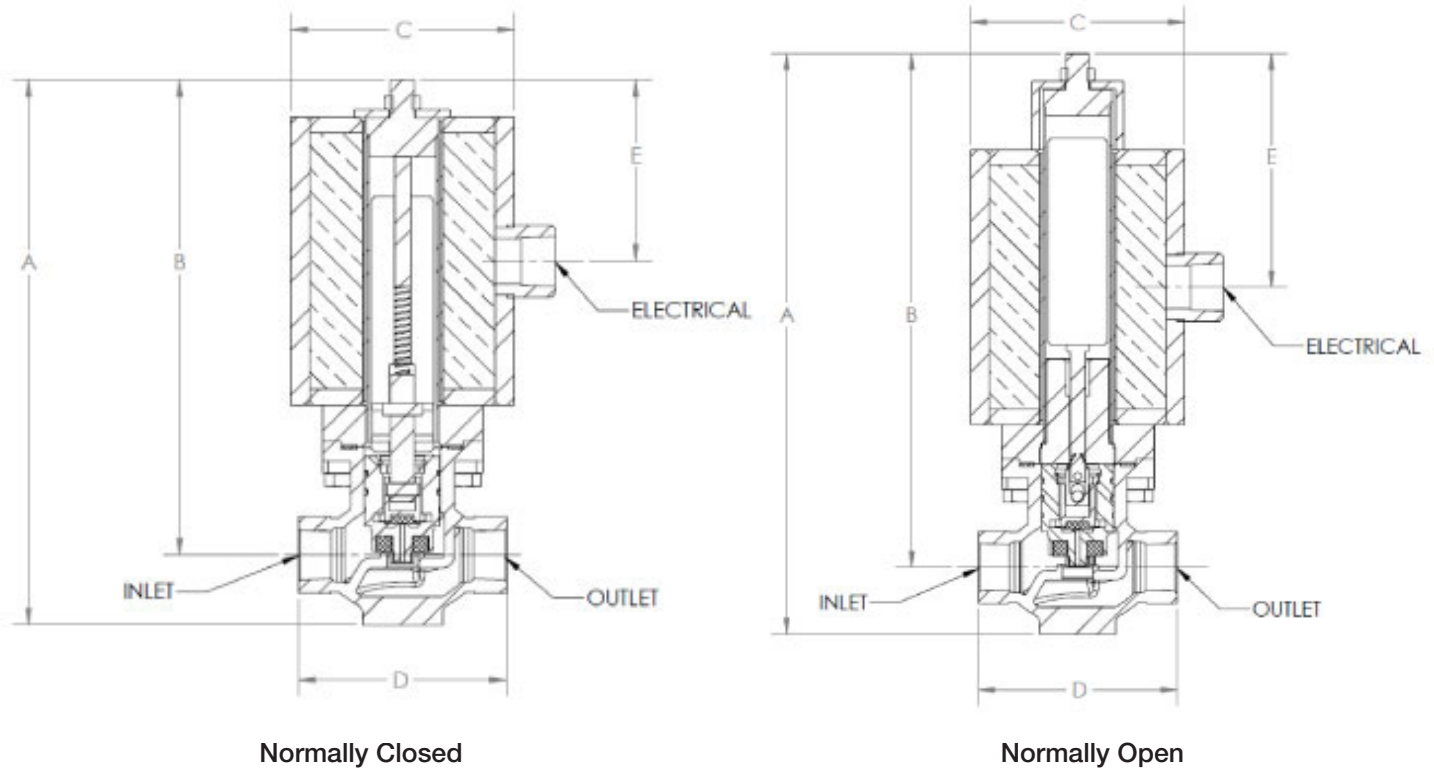

Reference Dimensions (Inches)											
Valve	Pipe Size	Normally	A	B	C	D					E
						NPT & Socket Weld	150# Flange**	300# Flange**	600# Flange	SAE	
EH70-08	1/2"	Closed	8.5	7.4	ø 3.5	3.25	5.50	6.00	6.50	N/A	2.8
		Open	9.5	8.4							3.8
EH70-12	3/4"	Closed	8.8	7.6	ø 3.5	3.50	5.75	6.50	7.00	N/A	2.8
		Open	9.7	8.6							3.8
EH70-16	1"	Closed	9.3	7.8	ø 3.5	4.13	7.00	7.25	7.75	N/A	2.8
		Open	10.3	8.8							3.8
EH70-24	1 1/2"	Closed	11.6	9.8	ø 4.5	4.94	7.63	8.25	8.94	N/A	3.3
		Open	12.7	10.8							4.5
EH70-32	2"	Closed	12.4	10.2	ø 4.5	6.00	9.00	9.63	10.38	N/A	3.3
		Open	13.7	11.4							4.5

** ANSI Raised Face

EH70 SERIES 1/2" TO 2" PIPE SIZE

Possible EH70 Options & Add-Ons



Cryogenic Service



72" Lead Length



Din Connector



Hydrogen Service



Normally Open

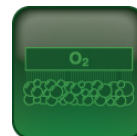

Oxygen Clean



ETL Certified - Explosion Proof



Stainless Steel Tags



Tube Connector



Single Switch



NEMA 4X



Class V Leakage Test



Manual Override

The following are standard on the EH70:



Stainless Steel Valve Body



Universal Mount
*1/2" and 3/4" only

Certifications



CRN
(Canadian Registration Number)



ETL Listed solenoid is an available option, at an additional price.

Conforms to UL Std. 1203
Certified to CAN/CSA Std. C22.2 No.30

*Consult Factory for Listing and Pricing Details.

EH70 SERIES

1/2" TO 2" PIPE SIZE

Construction

Valve Body:	316 SS (CF8M)
Piston:	303 SS
Piston Rings:	PTFE (cryo to 400°F)
Plunger:	430 SS
Pilot Valve:	303 SS
Bonnet Tube:	304 SS
Bonnet Base Flange:	304 SS
Spring:	302 SS
Gasket:	PTFE Based (Durlon 9000™)
Valve Disc:	PTFE

Flow & Wattage

Pipe & Orifice Size	Max Inlet Pressure (psig)	Cv	Coil	Voltages Available	Approx Current (amps)
1/2"	1500	3.5	200 Series	24V AC/DC	2.6
3/4"	1200	7.5		120V AC/DC	0.7
1"	1200	13		220V AC/DC	0.5
1 1/2"	1200	25	300 Series	24V AC/DC	3.6
				120V AC/DC	1.0
2"	1200	48		220V AC/DC	0.5

Pressures Reduced for "D" and "MN" Options.

Electrical (Coil)

Standard Coil:

- NEMA 4 (indoor/outdoor watertight)
- 1/2" NPT Female conduit connection
- 36" leads
- Continuous Service

Coil Option:

- ETL Listing for UL-1203, CAN/CSA C22.2 No. 30 certified for hazardous locations:
 - Explosion-Proof for Class I, Division 1, Groups A-D for Operating Temperature Code T2D
 - in -20 to +85 degrees C ambient; seal welded construction

Coil Option:

- NEMA 4x epoxy coating